



ICC-ES Evaluation Report ESR-4799

Reissued December 2022

Revised March 2024

This report is subject to renewal December 2024.

DIVISION: 05 00 00—METALS
Section: 05 52 00—Metal Railings
Section: 05 73 13—Glazed Decorative Metal Railings

DIVISION: 08 00 00—OPENINGS
Section: 08 81 00—Glass Glazing
Section: 08 88 00—Special Function Glazing

REPORT HOLDER:

IRON BALUSTER (DBA VIEWRAIL, DBA STAIRSUPPLIES)

EVALUATION SUBJECT:

BASE RAIL, TALON AND UNIVERSAL GLASS PIN GUARDRAIL SYSTEMS

1.0 EVALUATION SCOPE

Compliance with the following codes:

- 2021, 2018 and 2015 *International Building Code*® (IBC)
- 2021, 2018 and 2015 *International Residential Code*® (IRC)

For evaluation for compliance with codes adopted by Los Angeles Department of Building and Safety (LADBS), see [ESR-4799 LABC and LARC Supplement](#).

Property evaluated:

- Structural
- Durability

2.0 USES

The Base Rail and Talon guardrail systems are intended for use in interior and exterior locations of all construction types under the IBC or IRC. The Universal Standoff Pin guardrail system is intended for use in interior and exterior locations under the IRC.

The ¾" Base Rail system may also be used with or without a top rail in wind-borne debris regions in accordance with IBC Section 2407.1.4 when laminated glass panels with a minimum total nominal thickness of ¾ inch (19 mm) with a

minimum 0.035-inch (0.89 mm) thick SentryGlas® SG5000 interlayer are used.

3.0 DESCRIPTION

3.1 General: The Base Rail system utilizes continuous aluminum base shoes with glass clamp dry glazing mechanisms to secure the glass panels (See Figures 3 and 6). The Talon system utilizes Talon surface mounts to secure the glass panels (See Figure 8). The Universal Standoff Pin system utilizes standoff pin assemblies to secure the glass panels (See Figure 11).

All systems require the top rails and glass panels described in Sections 3.1.1 and 3.1.2, except for systems evaluated for installation without a top rail in accordance with Section 4.1.3.1.

3.1.1 Top Rail Assembly:

3.1.1.1 Top Rails: The top rails are required for all installations, except for the ¾" Base Rail system evaluated for installation without a top rail in accordance with Section 4.1.3.1. The top rails are manufactured from ASTM B221 6063-T6 aluminum. The dimensions of the top rail comply with the graspability requirements outlined in 2021, 2018, and 2015 IBC Section 1014.3.1 and 2021 and 2018 IRC Section R311.7.8.5 (2015 IRC Section R311.7.8.3). See Figure 1.

3.1.1.2 Glass U-Channel Gasket: The glass u-channel gasket is manufactured from flexible PVC as specified in the approved quality documentation. See Figure 2.

3.1.1.3 Silicone Adhesive: For systems in which the ends of the top rail are not attached to a wall or post, silicone adhesive is required to be applied in accordance with Section 4.1.1 of this report. The silicone adhesive must comply with ASTM C-1184 and ASTM C920 Type S, Grade NS and Uses NT, G and A.

3.1.2 Glass Panels:

3.1.2.1 Monolithic: The monolithic glass panels must be fully tempered (FT) glass complying with ASTM C1048, ANSI Z97.1 Class A and Category II of CPSC 16 CFR 1201 (procured separately). The glass panels must have a minimum Modulus of Rupture (Fr) ≥ 24,000 psi (165 MPa).

The glass panels must have a nominal thickness of ½-inch, and the minimum thickness of the glass panels must be at least 0.469 inch (11.9 mm).

Glass panels used with Universal Standoff Pin systems are prefabricated with holes, which are used for mounting with the associated hardware.

3.1.2.2 Laminated:

General: The laminated glass panels must comply with ASTM C1172 and ANSI Z97.1 Class A or Category II of CPSC 16 CFR 1201 (procured separately). The panels must consist of two lites of glass with an interlayer.

½" Panels: The total nominal thickness of the panels must be ½-inch. For panels utilizing a 0.035-inch-thick (0.89 mm) interlayer, the minimum actual panel thickness must be 0.473 inches (12 mm). For panels utilizing a 0.060-inch-thick (1.52 mm) interlayer, the minimum actual panel thickness must be 0.498 inches (12.6 mm).

¾" Panels: The total nominal thickness of the panels must be ¾-inch. For panels utilizing a 0.035-inch-thick (0.89 mm) interlayer, the minimum actual panel thickness must be 0.745 inches (18.9 mm).

Lites: The lites must be Kind FT tempered glass complying with ASTM C1048 and have a minimum Modulus of Rupture (F_r) \geq 24,000 psi (165 MPa).

3.2 Interlayer: The interlayer may be either 0.035-inch (0.89 mm) or 0.060-inch (1.52 mm) thick. The interlayer must be non-PVB with a minimum shear modulus of 3828 psi (26.4 MPa) for temperatures (T) \leq 122°F (50°C). Required interlayer thickness for each configuration is noted in Tables 1 through 6. **Base Rail System:** In addition to the components described in Section 3.1, the Base Rail systems are composed of the following components:

3.2.1 ½" Base Rail

3.2.1.1 Base Rail: The Base Rail base shoes are 54 inch (1372 mm) long sections manufactured from ASTM B221 6061-T6 aluminum. See Figure 3.

3.2.1.2 Glass Clamp Dry Glaze Mechanism: The glass clamp dry glaze mechanism supports consist of two metal plates containing 7/16-14 threaded extensions with 7/16-14 nuts factory-bonded to a Polyethylene Terephthalate Glycol (PETG) acrylic isolator. The metal plates are 3.75 inches by 2.55 inches by 0.12 inch thick (95 mm by 65 mm by 3 mm) and are composed of ASTM A240 316 stainless steel. See Figure 3.

3.2.1.3 Joining Pins: The joining pins are 0.185-inch (4.7 mm) diameter by 1.8 inches (45.7 mm) long and are constructed of ASTM B221 6061-T6 aluminum. See Figure 3.

3.2.1.4 Shims: The plastic shims measure 3.75 inches by 2.5 inches by 0.040 inch thick (95 mm by 63.5 mm by 1.0 mm) and are constructed from PETG material.

3.2.2 ¾" Base Rail

3.2.2.1 Base Rail: The Base Rail base shoes are 54 inch (1372 mm) long sections manufactured from ASTM B221 6061-T6 aluminum. See Figure 6.

3.2.2.2 Glass Clamp Dry Glaze Mechanism: The glass clamp dry glaze mechanism supports consist of two metal plates field-bonded to a Polyethylene Terephthalate Glycol (PETG) acrylic isolator. The metal plates are 3.75 inches by 2.55 inches by 0.12 inch thick (95 mm by 65 mm by 3 mm) and are composed of ASTM A240 316 stainless steel. See Figure 6.

3.2.2.3 Joining Pins: The joining pins are 0.185-inch (4.7 mm) diameter by 1.8 inches (45.7 mm) long and are constructed of ASTM B221 6061-T6 aluminum. See Figure 6.

3.2.2.4 Set Screw: The set screw is manufactured from ASTM B221 6061-T6 or 6005A-T61 aluminum. It is 0.550 inch (14 mm) long and 0.5 inch (12.7mm) in diameter, with 1/2-13 UNC threads. See Figure 6.

3.3 Talon System:

In addition to the components described in Section 3.1, the Talon system are composed of the following components:

3.2.3 Base: The Talon base measures 3.75 inches x 3.75 inches x 6.50 inches (95 mm by 95 mm by 165 mm) and is manufactured from ASTM B221 6061-T6 or 6005A-T61 aluminum. See Figure 8.

3.2.4 Glass Gasket: The glass gasket measures 4.78 inches x 0.62 inches x 0.60 inch thick (121.4 mm by 15.8 mm x 1.6 mm) PETG. See Figure 8.

3.2.5 Steel Pressure Plate: The Talon pressure plate (spacer plate) is manufactured from ASTM A240 304 stainless steel. The plate is 1.48 inches (37.6 mm) wide, 4 inches (102 mm) long, and 0.125 inch (3.18 mm) thick. See Figure 8.

3.2.6 Set Screw: The Talon set screw is manufactured from ASTM B221 6061-T6 or 6005A-T61 aluminum. It is 1 inch (25.4 mm) long and 0.5 inch (12.7mm) in diameter, with 1/2-13 UNC threads. See Figure 8.

3.3 Universal Standoff Pin System:

In addition to the components described in Section 3.1, the Universal Standoff Pin system is composed of the following glass pin assembly components. See Figure 11.

3.3.1 Standoff Pin Base: The standoff pin base is 1.98 inches (50.3 mm) in diameter, 1.15 inches (29.2 mm) long and manufactured from ASTM B221 6061-T6 or 6005A-T61 aluminum. See Figure 11.

3.3.2 Standoff Pin End Cap: The standoff pin end cap is 1.98 inches (50.3 mm) in diameter, 0.988 inch (25.1 mm) long and manufactured from ASTM B221 6061-T6 or 6005A-T61 aluminum. See Figure 11.

3.3.3 Standoff Pin Gaskets: The standoff pin gaskets are 1.94 inches (49.3 mm) in diameter and 0.09 inch (2.3 mm) in diameter. The gaskets are manufactured from ABS plastic. See Figure 11.

3.4 Durability:

The Base Rail, Talon and Universal Standoff Pin system materials supplied by Iron Baluster (dba Viewrail, dba Stairsupplies) are inherently corrosion-resistant. The material type specified must be appropriate for the environment of the installation. Information verifying the durability must be submitted to the code official, when requested.

4.0 DESIGN AND INSTALLATION

4.1 Installation: Installation of the guardrail systems, including the top rails, must comply with the manufacturer's published instructions, this report, and the IBC, as applicable.

The manufacturer's published installation instructions must be available at the jobsite at all times during installation. In the event of a conflict between this report and the manufacturer's instructions, this report governs.

4.1.1 Top Rails: The maximum panel widths in Tables 1 through 6 account for the capacities of the top rails. When required in Tables 1 through 6, the ends of the top rail must be supported by a wall or post, and the design of the attachment to the end support is outside of the scope of this report.

The top rail is secured to the glass panel with a rubber U channel gasket (see Figure 2).

When the top rail is installed without being attached to a wall or post, a $\frac{1}{8}$ inch (3.2 mm) bead of silicone adhesive complying with Section 3.1.1.3 must be applied to secure the top rail to the last three glass panels in a run in the following locations: between the top of the glass panel and the bottom of the U channel gasket and between the top of the U channel gasket and the bottom of the top rail.

4.1.2 $\frac{1}{2}$ " Base Rail System: The $\frac{1}{2}$ " Base Rail system is a dry glazing system where the glass panel is clamped inside the base shoe by the plastic shim and glass clamp dry glaze mechanism. The base shoes are surface mounted to the building substrate in accordance with the approved design, and adjacent base shoes are attached via joining pins. The glass is held in place by the compressive forces created by the shims and glass clamp dry glaze mechanisms; one shim is installed with each glass clamp dry glaze mechanism. Compressive forces are developed by tightening the glass clamp dry glaze mechanisms to the manufacturer's specifications using the Custom Base Rail Wrench, which is supplied by the manufacturer.

The glass clamp dry glaze mechanism is compatible with the base shoe and glass panel thickness listed in this report.

The glass clamp dry glaze mechanisms must be spaced as shown in Figure 4 for installations governed by the IBC; for installations governed by the IRC, the glass clamp dry glaze mechanisms must be spaced as shown in Figure 5. See Table 1 for installations governed by the IBC and Table 2 for installations governed by the IRC.

4.1.3 $\frac{3}{4}$ " Base Rail System: The $\frac{3}{4}$ " Base Rail system is a dry glazing system where the glass panel is clamped inside the base shoe by the glass clamp dry glaze mechanism. The base shoes are surface mounted to the building substrate in accordance with the approved design, and adjacent base shoes are attached via joining pins. The glass is held in place by the compressive forces created by the glass clamp dry glaze mechanisms; compressive forces are developed by tightening the glass clamp set screw dry glaze mechanisms to the manufacturer's specifications using a standard allen wrench.

The glass clamp dry glaze mechanism is compatible with the base shoe and glass panel thickness listed in this report.

The glass clamp dry glaze mechanisms must be spaced as shown in Figure 7 and Table 3 for installations governed by the IBC or IRC.

4.1.3.1 Installation of $\frac{3}{4}$ " Base Rail System Without a Top Rail: The $\frac{3}{4}$ " Base Rail system may be installed without a top rail or handrail when using laminated tempered glass panels with a 0.035-inch (0.89 mm) thick non-pvb interlayer meeting the requirements of Section 3.1.2.2. The panel dimensions and spacing must be as shown in Figure 7 for installations without a top rail.

Installation without a top rail complies with the Exceptions noted in IBC Section 2407.1.2 and IRC Section R308.4.4.1.

4.1.3.2 Installation of $\frac{3}{4}$ " Base Rail in Wind-Borne Debris Regions: When installed in wind-borne debris regions, the system must be installed with laminated glass

panels with a minimum total nominal thickness of $\frac{3}{4}$ inch (19 mm) and a minimum 0.035-inch (0.89 mm) thick SentryGlas® SG5000 interlayer. The system may be installed with or without a top rail. When installed as described in this section, the system is rated in accordance with IBC Section 2407.1.4 for use wind zones 1 through 4, in which missile levels A, B, C, or D are required in accordance with ASTM E1996 as modified by Section 1609.2.2 of the 2021 and 2018 IBC (Section 1609.1.2 of the 2015 IBC)

4.1.4 Talon System: The Talon system is a dry glazing system where the glass panel is clamped inside of the Talon assemblies. The Talon clamp assemblies are surface mounted to the building substrate in accordance with the approved design. The glass panel is installed into the clamp assemblies and the set screws are tightened to 40 lb-ft (54.2 N-m) of torque.

A minimum of two Talon clamp assemblies must be used on for each glass panel, and the clamps must be spaced 4 inches (102 mm) on centerline from the edge of the glass. See Table 4, Table 5, and Figure 9.

4.1.5 Universal Standoff Pin System: The Universal Standoff Pin system is a dry glazing system where the glass panel is clamped inside of the Universal Standoff Pin assemblies. The Universal Standoff Pin assemblies are fascia mounted to the building substrate or stair treads in accordance with the approved design. The holes in the prefabricated glass panels are installed over the bushings in the Universal Standoff Pin assemblies and the glass pin caps are tightened to the outer face of the glass panels. The glass pin caps are tightened to the manufacturer's specifications using the Glass Pin Spanner Wrench, which is supplied by the manufacturer.

For level glass railing installations shown in Figure 12, glass panel widths between 42 and 54 inches (1067 and 1372 mm) in width require a minimum of 3 sets of standoff pins (6 total); glass panel widths less than 42 inches (1067 mm) require a minimum of 2 sets of standoff pins (4 total). Figure 13 outlines the design limitations for use of pins on stair systems, and Figure 14 outlines the design limitations for use of a single row of pins.

4.2 Design: Live Loads: The following project specific live loads must be identified while limiting edge stresses within the glass panels to 6,000 psi (41.3 MPa), surface stresses within the glass panels to 7,875 psi (54.3 MPa) and the deflection to 1 inch (25.4 mm) or less:

A live load of 50 plf (730 N/m) applied in any direction along the top rail (IBC only).

A single concentrated live load of 200 pounds (0.89 kN) applied in any direction at any point on the top of glass panel (IBC and IRC).

A horizontally applied normal live load of 50 pounds (0.22 kN) applied perpendicular to the glass panel on an area not to exceed 12 inches-by-12 inches (305 mm-by-305 mm) [IBC and IRC].

4.2.2 Wind Loads: The allowable stress for the Base Rail System due to wind loading is 10,600 psi (66.2 MPa) for edge stresses and 13,500 psi (93.1 MPa) for surface stresses. The required wind load must be determined by a registered design professional based on the project-specific conditions, taking into account the balustrade location on the structure, and must not exceed the values shown in the tables of this report. The $\frac{1}{2}$ " Base Rail guardrail systems allowable wind load capacities are provided in Table 1 for

installations governed by the IBC and in Table 2 for installations governed by the IRC. The 3/4" Base Rail guardrail systems allowable wind load capacities are provided in Table 3 for installations governed by the IBC or IRC. The Talon guardrail systems allowable wind load capacities are provided in Table 5 for installations governed by the IBC and in Table 4 for installations governed by the IRC. The Universal Standoff Pin systems allowable wind load capacities are provided in Table 6 for installations governed by the IRC.

5.0 CONDITIONS OF USE

The Base Rail, Talon and Universal Standoff Pin guardrail systems described in this report comply with, or are a suitable alternative to what is specified in, those codes listed in Section 1.0 of this report, subject to the following conditions:

- 5.1 The Universal Standoff Pin System described in Table 6 is limited to installations governed by the IRC.
- 5.2 Installation of the assemblies with monolithic glass in installations governed by the IBC, when noted in the applicable tables of this report, are restricted to locations in which there is no walking surface beneath them or locations in which the walking surface is permanently protected from the risk of falling glass as outlined in Section 2407.1 of the IBC.
- 5.3 3/4" Base Rail systems are limited to use with the laminated glass described in Table 3.
- 5.4 The products are limited to installation where they are not subject to vehicle impacts.
- 5.5 The supporting structure and anchorage of the systems to the supporting structure is outside of the scope of this report and must be designed by a registered design professional and constructed to support the loads imposed by the guards in accordance with the applicable code.
- 5.6 Drawings and design details for the Base Rail, Talon and Universal Standoff Pin guardrail systems, using the information noted in this report, must be included on construction plans submitted to the code official for approval where required by the local jurisdiction. The drawings and details must be prepared by a registered design professional where required by the statutes of the jurisdiction in which the project is to be constructed.
- 5.7 When installed where the system anchors are exposed to moisture, the system anchors must be of a material intended for the use and identified by the manufacturer as acceptable for exterior applications.
- 5.8 All metals in contact with aluminum must either be an alloy approved for direct aluminum contact, or isolated from the aluminum by an approved coating.
- 5.9 Both ends of the top rails, when used, must be supported by a wall or post, and the attachment must be capable of supporting a concentrated horizontal load of 200lbs (0.89 kN) unless noted otherwise Tables 1, 2, 3, 4, 5, and 6.

- 5.10 Glass sand-blasted or etched on surfaces 1 (outside face) or 2 (inside face) is outside the scope of this report.
- 5.11 Use of the systems as a grab bar is outside the scope of this report.
- 5.12 All monolithic glass panels must be fully tempered glass complying with Section 3.1.2.1 and must be fabricated and inspected in accordance with ASTM C1048. The glass fabricator must provide certification of compliance with ASTM C1048. Glass must be procured directly from a qualified glass fabricator.
- 5.13 All laminated glass panels must be fully tempered Type II laminated glass, with an interlayer complying with Section 3.1.2.2, and fabricated and inspected in accordance with ASTM C1172. The glass fabricator must provide certification for compliance with ASTM C1048 for fully tempered glass or ASTM C1172 for laminated glass, as applicable. Glass must be procured directly from a qualified glass fabricator.
- 5.14 The Base Rail, Talon and Universal Standoff Pin guardrail system components listed in this report, except for the glass panels and silicone adhesive are supplied by Iron Baluster (dba Viewrail, dba Stairsupplies).

6.0 EVIDENCE SUBMITTED

Data in accordance with the ICC-ES Acceptance Criteria for Glass Railing and Balustrade Systems (AC439) dated April 2019 (editorially revised August 2020).

7.0 IDENTIFICATION

- 7.1 The ICC-ES mark of conformity, electronic labeling, or the evaluation report number (ICC-ES ESR-4799) along with the name, registered trademark, or registered logo of the report holder must be included in the product label.
- 7.2 In addition, the Universal Standoff Pin guardrail system components described in this report are identified by a label on the packaging bearing the product description and/or part number. The Universal Standoff Pin guardrail system shall additionally be labeled with the following language, "For Use in One- and Two-Family Dwellings Only."
- 7.3 The glass panels must be identified as specified in the applicable code.
- 7.4 The report holder's contact information is the following:
IRON BALUSTER (DBA VIEWRAIL, DBA STAIRSUPPLIES)
1722 EISENHOWER DRIVE NORTH
GOSHEN IN, 46526
1-866-261-8013
www.viewrail.com
www.stairsupplies.com

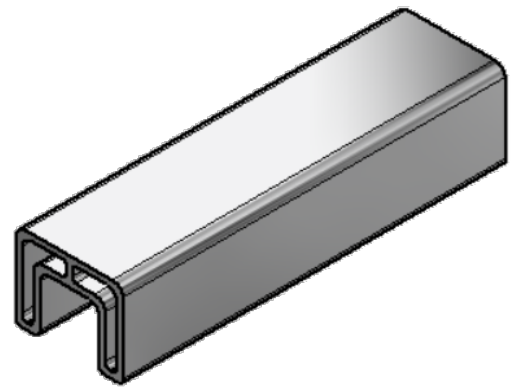
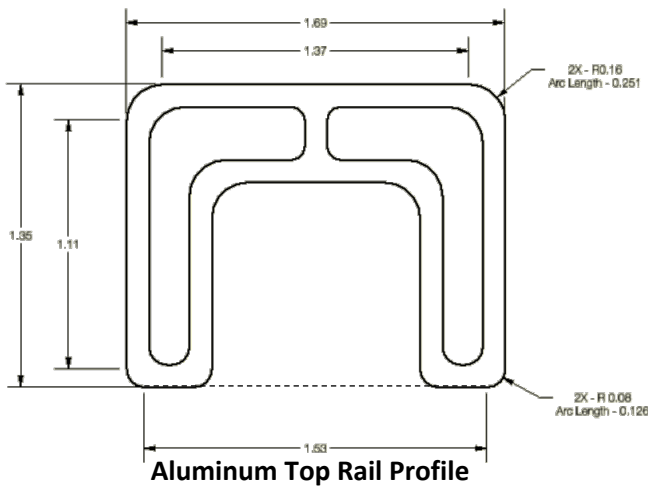

FIGURE 1—ALUMINUM TOP RAIL PROFILE
(For use with the 1/2" Base Rail, 3/4" Base Rail, Talon, and Universal Standoff Pin guardrail systems)

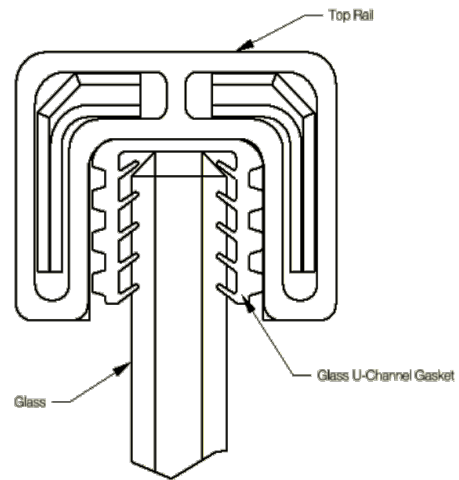
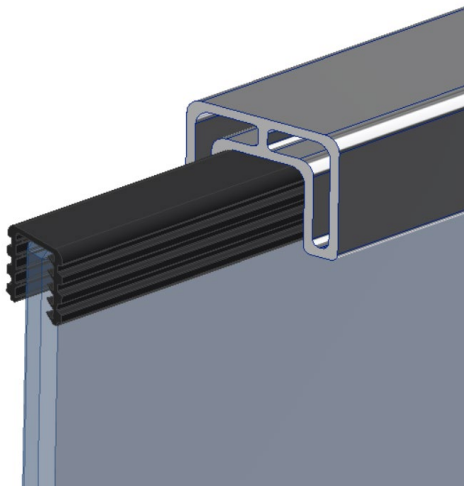

FIGURE 2—TOP RAIL ATTACHMENT
(For use with the 1/2" Base Rail, 3/4" Base Rail, Talon, and Universal Standoff Pin guardrail systems)

TABLE 1—ALLOWABLE DIMENSIONS AND WIND LOADS FOR 1/2" BASE RAIL SYSTEM (IBC or IRC)^{1,2,7}

MAXIMUM MIDDLE GLASS PANEL WIDTH (in.)	MAXIMUM END GLASS PANEL WIDTH (in.) ³	MAXIMUM GUARD HEIGHT (H _g ²), in. ^{4,5}	ALLOWABLE (ASD) WIND PRESSURE (w _{all wind} ⁶), psf
54	48	42	77

For SI: 1 inch = 25.4 mm; 1 psf = 47.9 Pa

1. A top rail must be installed in all situations.
2. Base Rail clamps must be spaced as shown in Figure 4.
3. For end glass panel widths of 48-inches or less, attachment to a wall or post is not required. When the top rail is adequately supported by a wall or post, the maximum end panel width may be greater than the tabulated maximum end panel width (48 inches) but no greater than the maximum middle panel glass width (54 inches).
4. Based on an allowable live load edge stress of 6000 psi, an allowable live load surface stress of 7875 psi and an allowable deflection of 1-inch when a 50 plf live load or 50 lb concentrated load are considered in accordance with Section 1607.9 of the 2021 IBC (Section 1607.8 of the 2018 and 2015 IBC). Other live loads listed in Section 4.2.1 must also be considered.
5. Glass height above floor, H_g.
6. w_{all wind} is based on an allowable wind load edge stress of 10600 psi and allowable wind load surface stress of 13500 psi.
7. 1/2-inch thick nominal monolithic glass complying with section 3.1.2.1 or 1/2-inch thick nominal laminated glass with a 0.06-inch (1.52 mm) thick interlayer complying with Section 3.1.2.2 must be used. See Figure 4 for glass panel dimension requirements.

TABLE 2—ALLOWABLE DIMENSIONS AND WIND LOADS FOR 1/2" BASE RAIL SYSTEM (IRC only)^{1,2,3,8}

MAXIMUM GLASS PANEL WIDTH (in.) ⁴	MAXIMUM END GLASS PANEL WIDTH (in.) ⁴	MAXIMUM GUARD HEIGHT (H _g ²), in. ^{5,6}	ALLOWABLE WIND PRESSURE (w _{all wind} ^{7,8}), psf
54	48	42	50

For SI: 1 inch = 25.4 mm; 1 psf = 47.9 Pa

1. Installations are limited to projects governed by the IRC.
2. A top rail must be installed in all situations.
3. Base Rail clamps must be spaced as shown in Figure 5.
4. For end glass panel widths of 48-inches or less, attachment to a wall or post is not required. When the top rail is adequately supported by a wall or post, the maximum end panel width may be greater than the tabulated maximum end panel width (48 inches) but no greater than the maximum middle panel glass width (54 inches).
5. Based on an allowable live load edge stress of 6000 psi, an allowable live load surface stress of 7875 psi and an allowable deflection of 1-inch when a 200 lb concentrated live load or 50lb concentrated live load are considered in accordance with Section R301.5 of the IRC.
6. Glass height above floor, H_g.
7. w_{all wind} is based on an allowable wind load edge stress of 10600 psi and allowable wind load surface stress of 13500 psi.
8. 1/2-inch thick nominal monolithic glass complying with section 3.1.2.1 or 1/2-inch thick nominal laminated glass with a .060-inch (1.52 mm) thick interlayer complying with Section 3.1.2.2 must be used. See Figure 5 for glass panel dimension requirements.

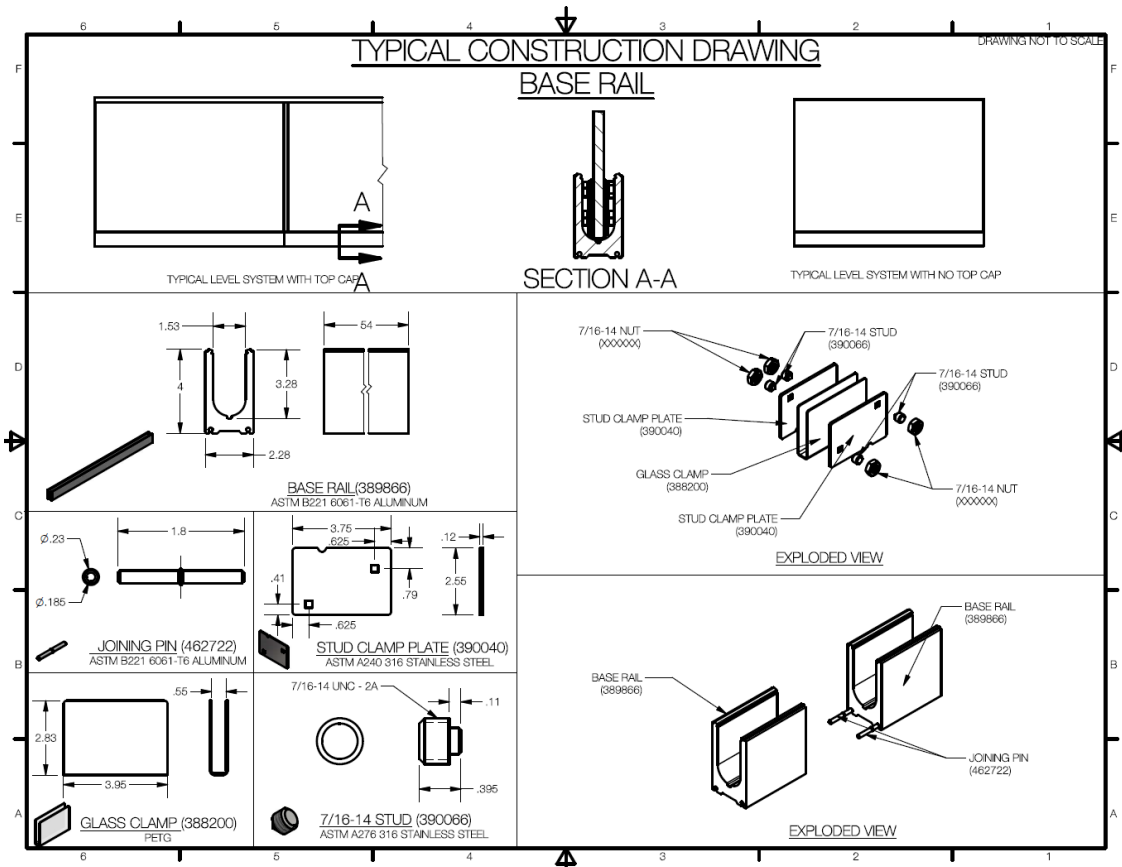
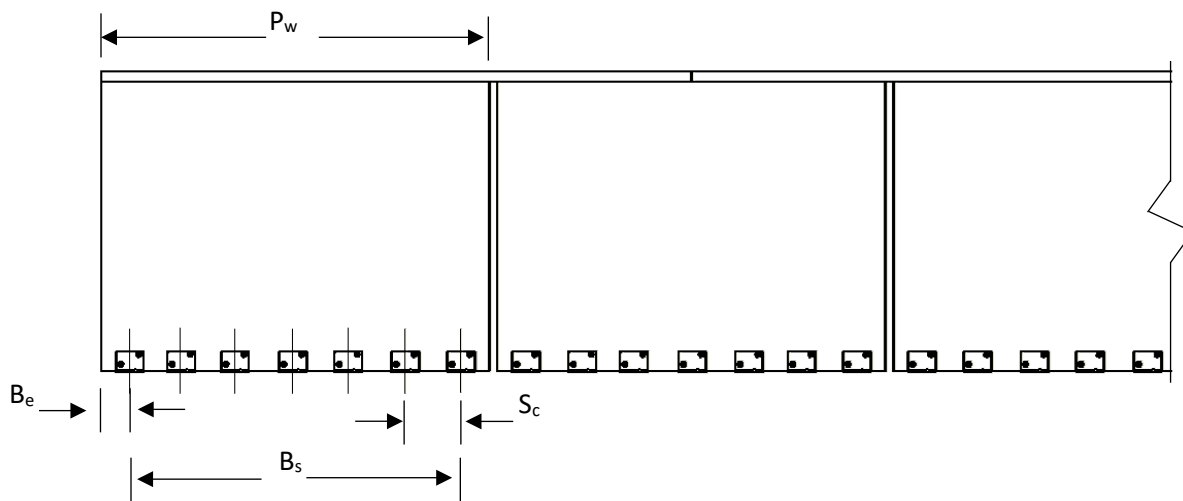
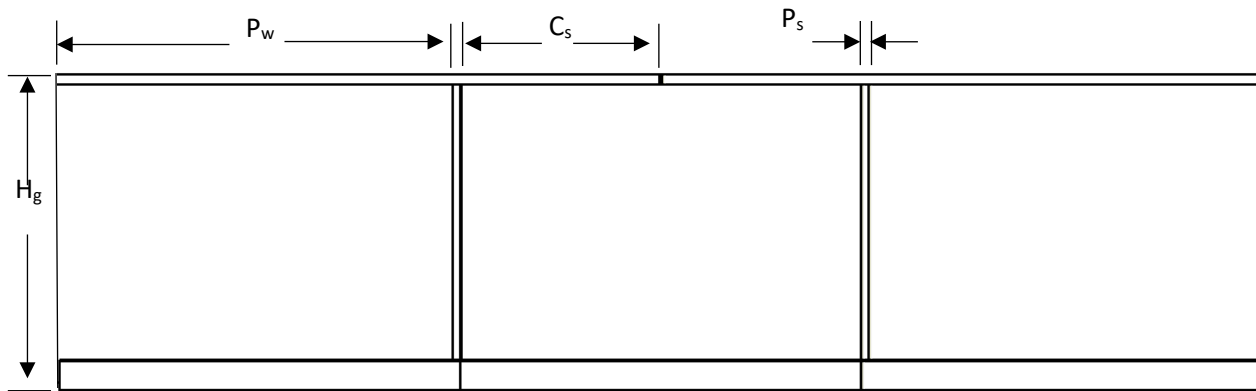

FIGURE 3: 1/2" BASE RAIL SYSTEM



			½-inch Monolithic Glass	½-inch Laminate Glass ⁴
H_g	Guard Height	H_{gmax}	Maximum Guard Height	42"
		H_{gmin}	Minimum Guard Height	12"
P_w	Glass Panel Width	P_{wmax}	Maximum Glass Panel Width	54"
		P_{wmin}	Minimum Glass Panel Width	12"
C_s	Top Rail Coupler Spacing		$0.5P_w$	$0.5P_w$
P_s	Spacing Between Glass Panels	P_{smax}	Maximum Spacing Between Glass Panels	1"
		P_{smin}	Minimum Spacing Between Glass Panels	0.25"
S_c	Spacing Between Glass Clamps	S_{cmax}^1	Maximum Spacing Between Clamps (On Center)	7.75"
B_e	Clamp Centerline to Glass Panel Edge		4"	4"
B_s	End Clamp Centerline to End Clamp Centerline Spacing		$P_w - 2B_e$	$P_w - 2B_e$

For SI: 1 inch = 25.4 mm

¹ A minimum of two glass clamp dry glaze mechanisms are required for each glass panel.

² Installation must also comply with Table 1.

³ Use of top rail coupler on end panels is not permitted unless end of top rail is supported adequately by a wall or post.

⁴ Laminate glass with a 0.06 inch (1.52 mm) interlayer is required.

FIGURE 4 — ½" BASERAIL CLAMP SPACING REQUIREMENTS ON GLASS PANELS (IBC or IRC)²

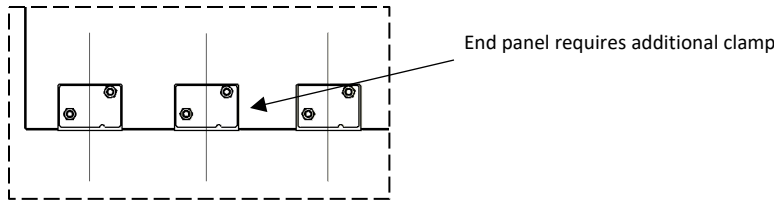
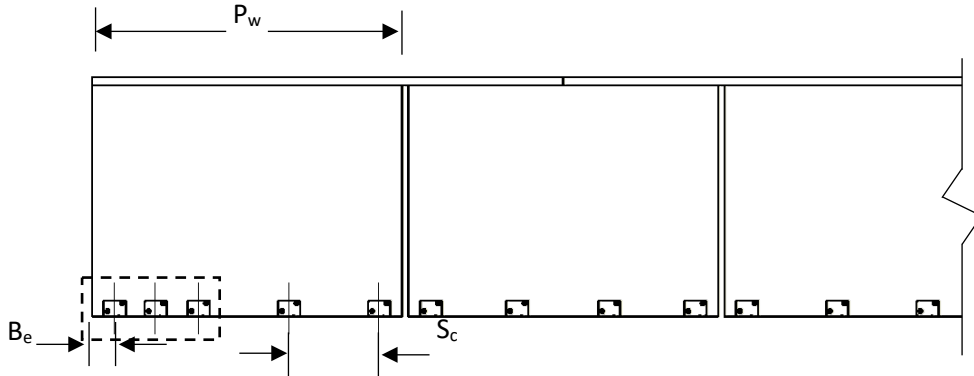
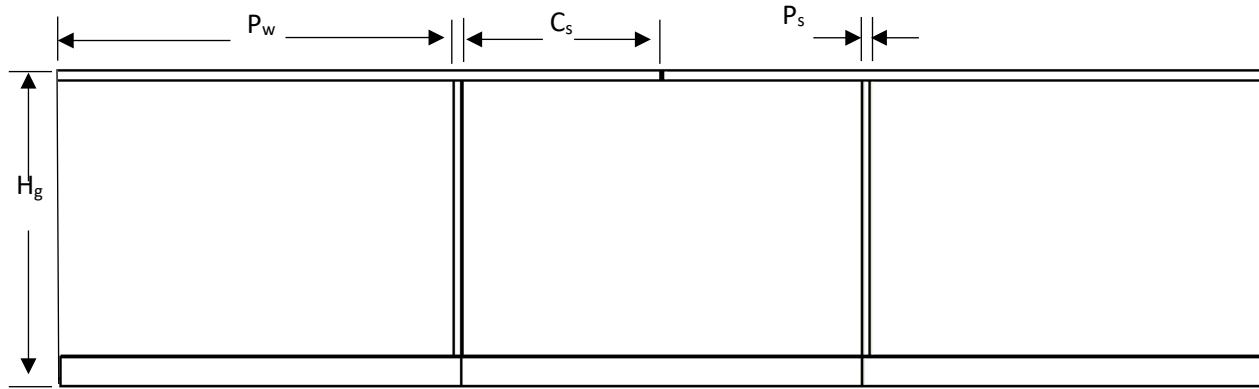

			1/2-inch Monolithic Glass	1/2-inch Laminated Glass ⁴
H_g	Guard Height	H_{gmax}	Maximum Guard Height	42"
		H_{gmin}	Minimum Guard Height	12"
P_w	Glass Panel Width	P_{wmax}	Maximum Glass Panel Width	54"
		P_{wmin}	Minimum Glass Panel Width	12"
C_s	Top Rail Coupler Spacing		$0.5P_w$	$0.5P_w$
P_s	Spacing Between Glass Panels	P_{smax}	Maximum Spacing Between Glass Panels	1"
		P_{smin}	Minimum Spacing Between Glass Panels	0.25"
S_c	Spacing Between Glass Clamps	S_{cmax} ¹	Maximum Spacing Between Clamps (On Center)	15.325"
B_e	Clamp Centerline to Glass Panel Edge		4"	4"
B_s	End Clamp Centerline to End Clamp Centerline Spacing		$P_w - 2B_e$	$P_w - 2B_e$

For SI: 1 inch = 25.4 mm

¹ A minimum of two glass clamp dry glaze mechanisms are required for each glass panel.

² Installation must also comply with Table 2.

³ Use of top rail coupler on end panels is not permitted unless end of top rail is supported adequately by a wall or post.

⁴ Laminated glass with a 0.06 inch (1.52 mm) interlayer is required.

FIGURE 5 — 1/2" BASERAIL CLAMP SPACING REQUIREMENTS ON GLASS PANELS (IRC ONLY)²

TABLE 3—ALLOWABLE DIMENSIONS AND WIND LOADS FOR 3/4" BASE RAIL SYSTEM (IBC or IRC)^{1,2,7}

MAXIMUM MIDDLE GLASS PANEL WIDTH (in.)	MAXIMUM END GLASS PANEL WIDTH (in.) ³	MAXIMUM GUARD HEIGHT (H _g) ² , in. ^{4,5}	ALLOWABLE (ASD) WIND PRESSURE (w _{all wind}) ⁶ , psf
54	48	42	77

For SI: 1 inch = 25.4 mm; 1 psf = 47.9 Pa

- System can be used with or without a top rail. When used without a top rail, panel spacing must be as shown in Figure 7.
- Base Rail clamps must be spaced as shown in Figure 7.
- For end glass panel widths of 48-inches or less, attachment of the top rail to a wall or post is not required. When the top rail is adequately supported by a wall or post, the maximum end panel width may be greater than the tabulated maximum end panel width (48 inches) but no greater than the maximum middle panel glass width (54 inches).
- Based on an allowable live load edge stress of 6000 psi, an allowable live load surface stress of 7875 psi and an allowable deflection of 1-inch when a 50 plf live load or 50 lb concentrated load are considered in accordance with Section 1607.9 of the 2021 IBC (Section 1607.8 of the 2018 and 2015 IBC). Other live loads listed in Section 4.2.1 must also be considered.
- Glass height above floor, H_g.
- w_{all wind} is based on an allowable wind load edge stress of 10600 psi and allowable wind load surface stress of 13500 psi.
- 3/4-inch thick nominal laminated glass with a 0.035-inch (0.89 mm) thick interlayer complying with Section 3.1.2.2 must be used. See Figure 7 for glass panel dimension requirements.

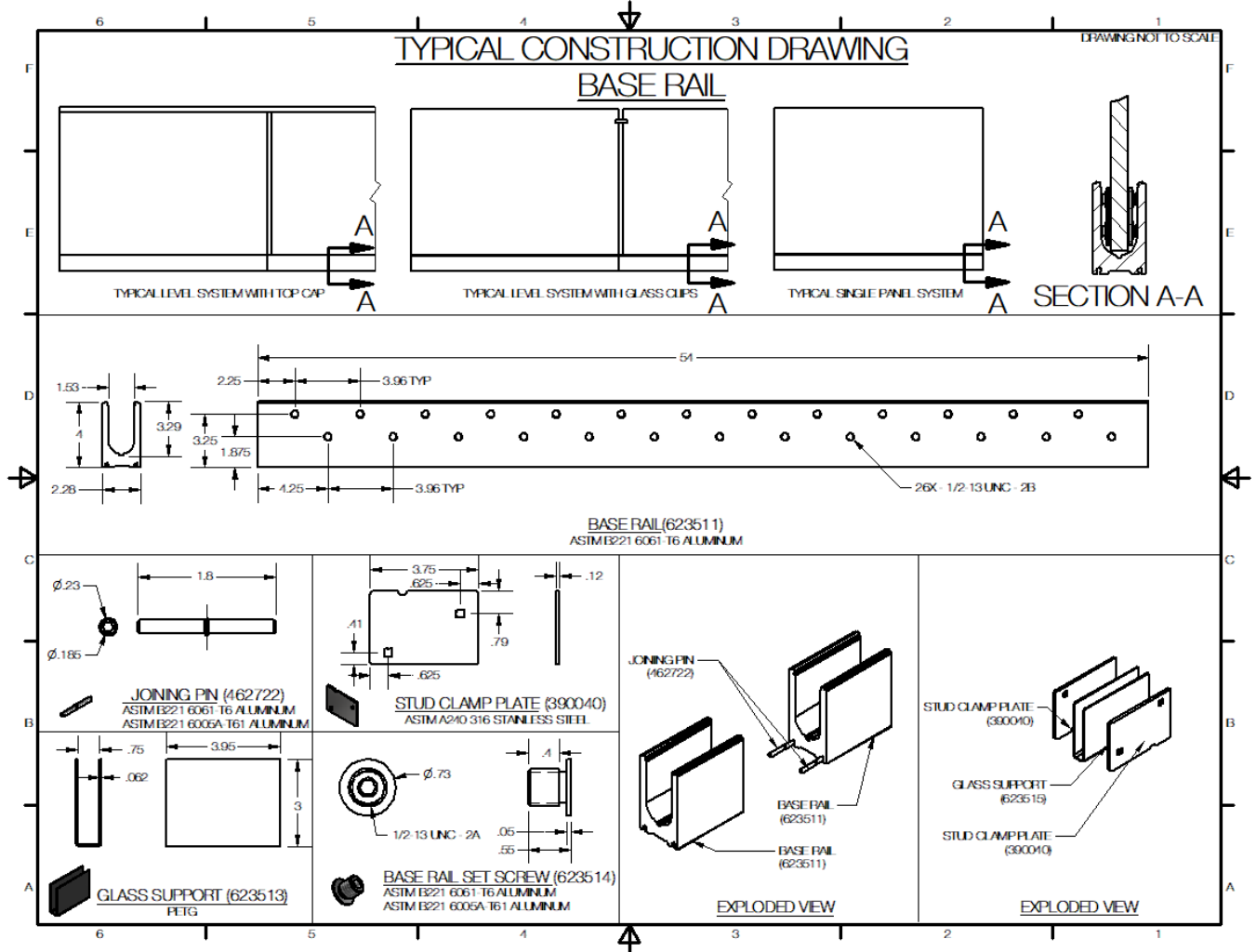
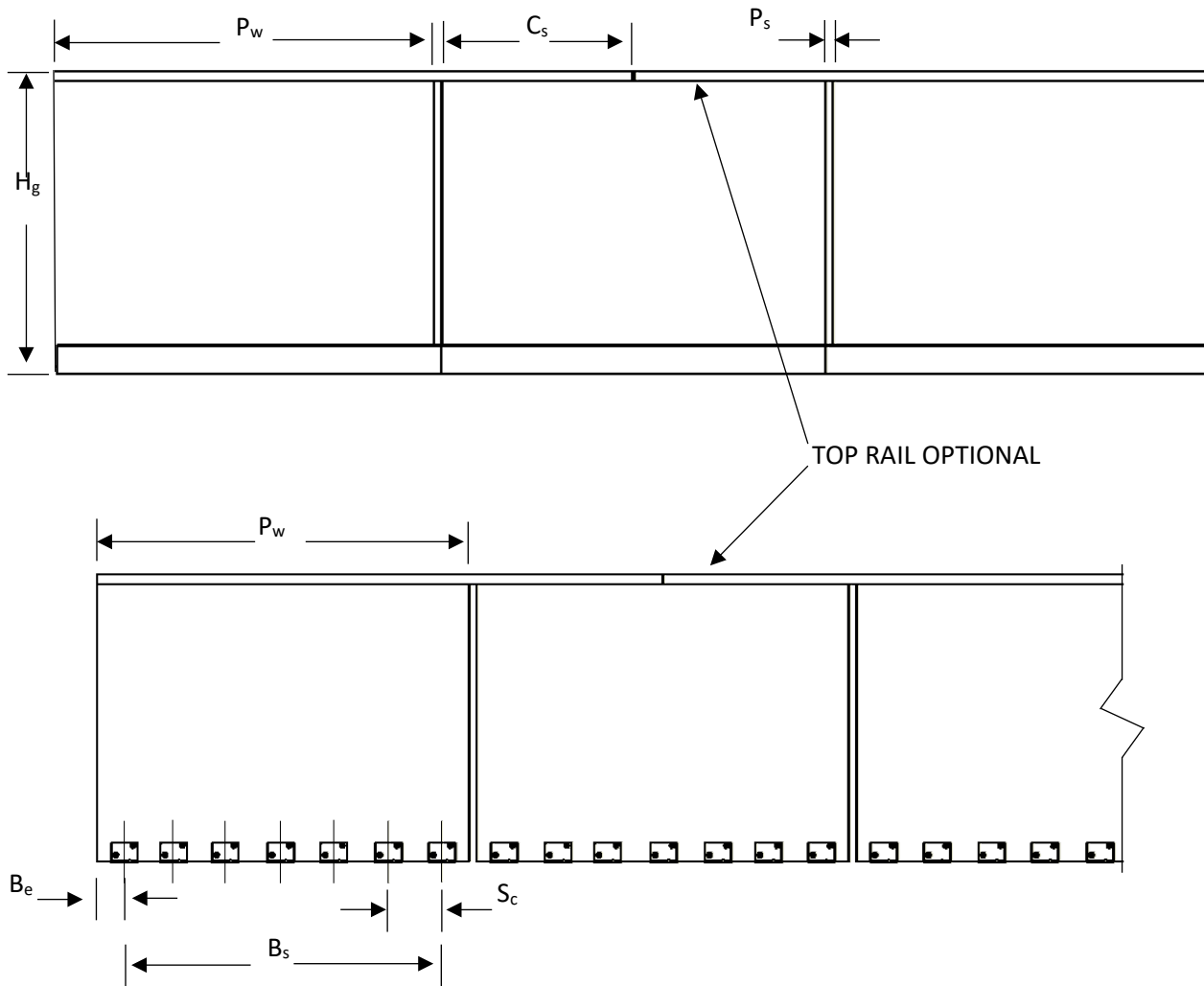

FIGURE 6: 3/4" BASE RAIL SYSTEM



			3/4-inch Laminate Glass w/ Top Rail	3/4-inch Laminate Glass w/o Top Rail
H_g	Guard Height	H _{gmax}	Maximum Guard Height	42"
		H _{gmin}	Minimum Guard Height	8"
P_w	Glass Panel Width	P _{wmax}	Maximum Glass Panel Width	54"
		P _{wmin}	Minimum Glass Panel Width	28"
C_s	Top Rail Coupler Spacing		0.5P _w	n/a
P_s	Spacing Between Glass Panels	P _{smax}	Maximum Spacing Between Glass Panels	1"
		P _{smin}	Minimum Spacing Between Glass Panels	0.25"
S_c	Spacing Between Glass Clamps	S _{cmax} ¹	Maximum Spacing Between Clamps (On Center)	7.75"
B_e	Clamp Centerline to Glass Panel Edge		4"	4"
B_s	End Clamp Centerline to End Clamp Centerline Spacing		P _w -2B _e	P _w -2B _e

For SI: 1 inch = 25.4 mm

¹ A minimum of two glass clamp dry glaze mechanisms are required for each glass panel.

² Installation must also comply with Table 6.

³ Use of top rail coupler on end panels is not permitted unless end of top rail is supported adequately by a wall or post.

⁴ Laminate glass with a 0.035-inch (0.89 mm) thick interlayer complying with Section 3.1.2.2 must be used.

FIGURE 7 — 3/4" BASERAIL CLAMP SPACING REQUIREMENTS ON GLASS PANELS (IBC or IRC)²

TABLE 4—ALLOWABLE DIMENSIONS AND WIND LOADS FOR TALON SYSTEM (IBC or IRC)^{1,2,7}

MAXIMUM MIDDLE GLASS PANEL WIDTH (in.)	MAXIMUM END GLASS PANEL WIDTH (in.) ³	MAXIMUM GUARD HEIGHT (H _g ²), in. ^{4,5}	ALLOWABLE WIND PRESSURE (w _{all wind} ⁶), psf
54	48	42	40

For SI: 1 inch = 25.4 mm; 1 psf = 47.9 Pa

1. A top rail must be installed in all situations.
2. Talons must be spaced as shown in Figure 9.
3. For end glass panel widths of 48-inches or less, attachment to a wall or post is not required. When the top rail is adequately supported by a wall or post, the maximum end panel width may be greater than the tabulated maximum end panel width (48 inches) but no greater than the maximum middle panel glass width (54 inches).
4. Based on an allowable live load edge stress of 6000 psi, an allowable live load surface stress of 7875 psi and an allowable deflection of 1-inch when a 50 plf live load or 50 lb concentrated load are considered in accordance with Section 1607.9 of the 2021 IBC (Section 1607.8 of the 2018 and 2015 IBC). Other live loads listed in Section 4.2.1 must also be considered.
5. Glass height above floor, H_g.
6. w_{all wind} is based on an allowable wind load edge stress of 10600 psi and allowable wind load surface stress of 13500 psi.
7. ½-inch thick nominal monolithic glass complying with section 3.1.2.1 or ½-inch thick nominal laminated glass with a 0.06-inch (1.52 mm) thick interlayer complying with Section 3.1.2.2 must be used. See Figure 9 for glass panel dimension requirements.

TABLE 5—ALLOWABLE DIMENSIONS AND WIND LOADS FOR TALON SYSTEM (IRC ONLY)^{1,2,8}

MAXIMUM MIDDLE GLASS PANEL WIDTH (in.)	MAXIMUM END GLASS PANEL WIDTH (in.) ³	MAXIMUM GUARD HEIGHT (H _g ²), in. ^{4,5}	ALLOWABLE WIND PRESSURE (w _{all wind} ^{6,7}), psf
54	48	42	25

For SI: 1 inch = 25.4 mm

1. A top rail must be installed in all situations.
2. Talons must be spaced as shown in Figure 10
3. For end glass panel widths of 48-inches or less, attachment to a wall or post is not required. When the top rail is adequately supported by a wall or post, the maximum end panel width may be greater than the tabulated maximum end panel width (48 inches) but no greater than the maximum middle panel glass width (54 inches).
4. Glass height above floor, H_g.
5. Based on an allowable live load edge stress of 6000 psi and an allowable deflection of 1-inch when a 200 lb concentrated live load or 50 lb concentrated live load are considered in accordance with Section R301.5 of the IRC.
6. Allowable wind pressure can be increased to 28 psf if H_g=39" or 30 psf if H_g=36"
7. w_{all wind} is based on an allowable wind load edge stress of 10600 psi and allowable wind load surface stress of 13500 psi.
8. ½-inch thick nominal monolithic glass complying with section 3.1.2.1 or ½-inch thick nominal laminated glass with a .035-inch (0.89 mm) thick interlayer complying with section 3.1.2.2 must be used. See Figure 10 for glass panel dimension requirements.

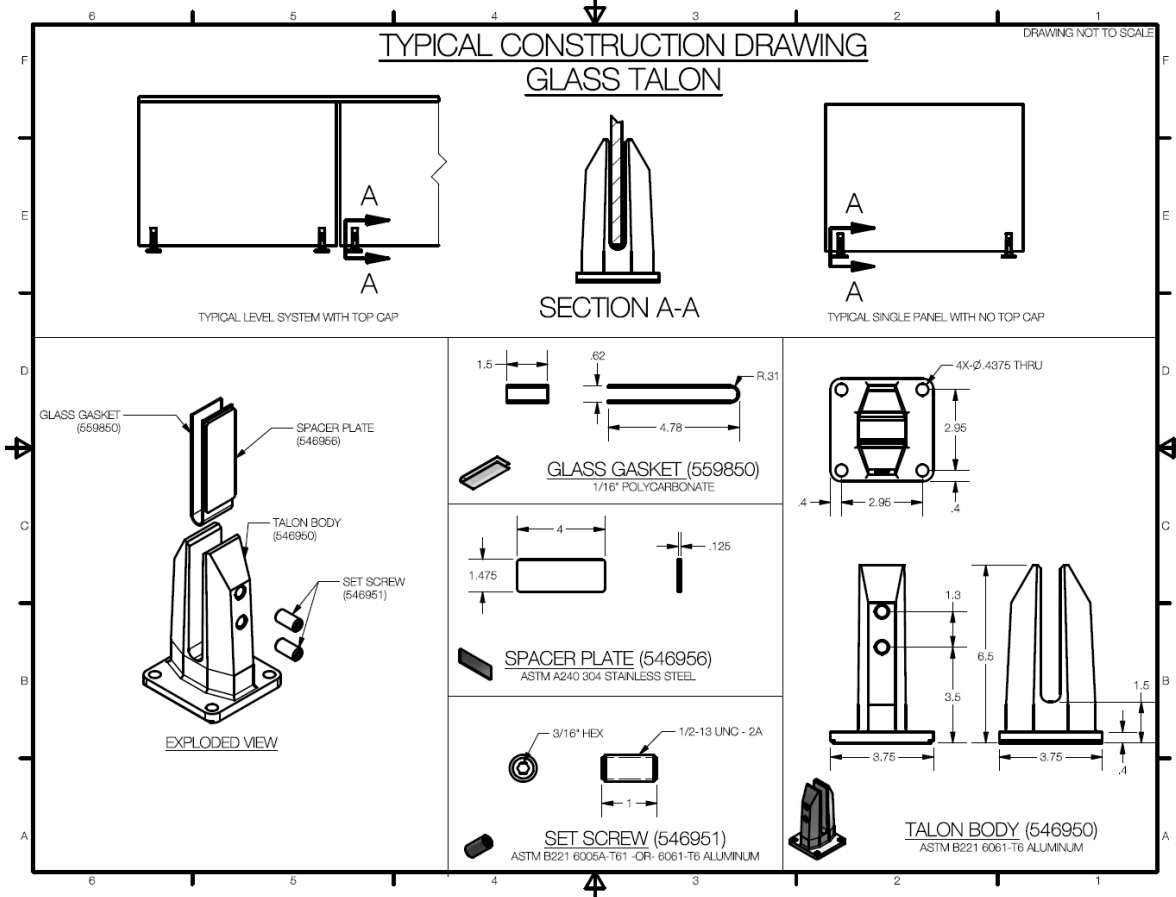
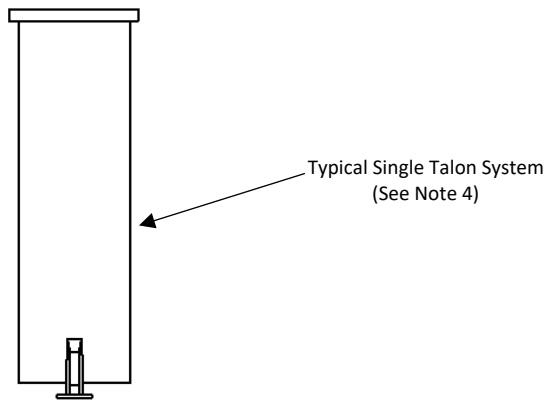
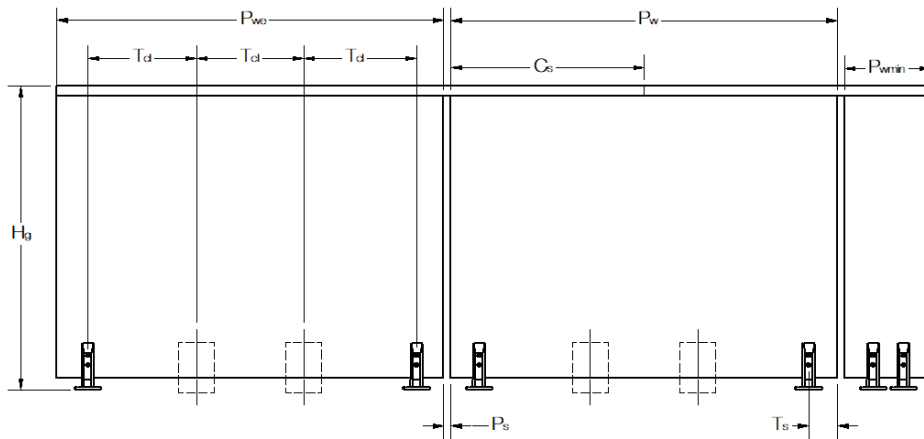

FIGURE 8: TALON SYSTEM



			1/2-inch Monolithic Glass	1/2-inch Laminate Glass ⁶
H _g	Guard Height	H _{gmax}	Maximum Guard Height	42"
		H _{gmin}	Minimum Guard Height	24"
P _w	Glass Panel Width	P _{wmax}	Maximum Glass Panel Width	54"
		P _{wmin} ³	Minimum Glass Panel Width	24"
P _{we} ¹	End Glass Panel Width	P _{wemax} ¹	Maximum End Glass Panel Width	48"
		P _{wemin} ¹	Minimum End Glass Panel Width	24"
P _s	Spacing Between Glass Panels	P _{smax}	Maximum Spacing Between Glass Panels	1"
		P _{smin}	Minimum Spacing Between Glass Panels	0.25"
T _{cl}	Talon Spacing (Centerline)	T _{clmax}	Maximum Space Between Talon (Centerline)	16"
T _s	Talon Centerline to Glass Panel Edge			4"
C _s	Top Rail Coupler Spacing			0.5P _w
T _x ⁴	Minimum Number of Talons Per Panel			2

For SI: 1 inch = 25.4 mm

¹ If top rail is adequately supported by post or wall on end, P_{wemax} can be increased to P_{wmax}.

² Installation must also comply with Table 3.

³ Single panel minimum glass panel width (laminated or monolithic) of 12" supported by two talons is permissible with top rail adequately supported by wall or post at both ends.

⁴ Single glass panel width (laminated or monolithic) between 4" and 12" allowed supported by a single talon when top rail is adequately supported by a wall or post on both ends.

⁵ Use of top rail coupler on end panels is not permitted unless end of top rail is supported adequately by a wall or post.

⁶ Laminate glass with a 0.06 inch (1.52 mm) interlayer is required.

FIGURE 9 – TALON ASSEMBLY² (IBC or IRC)

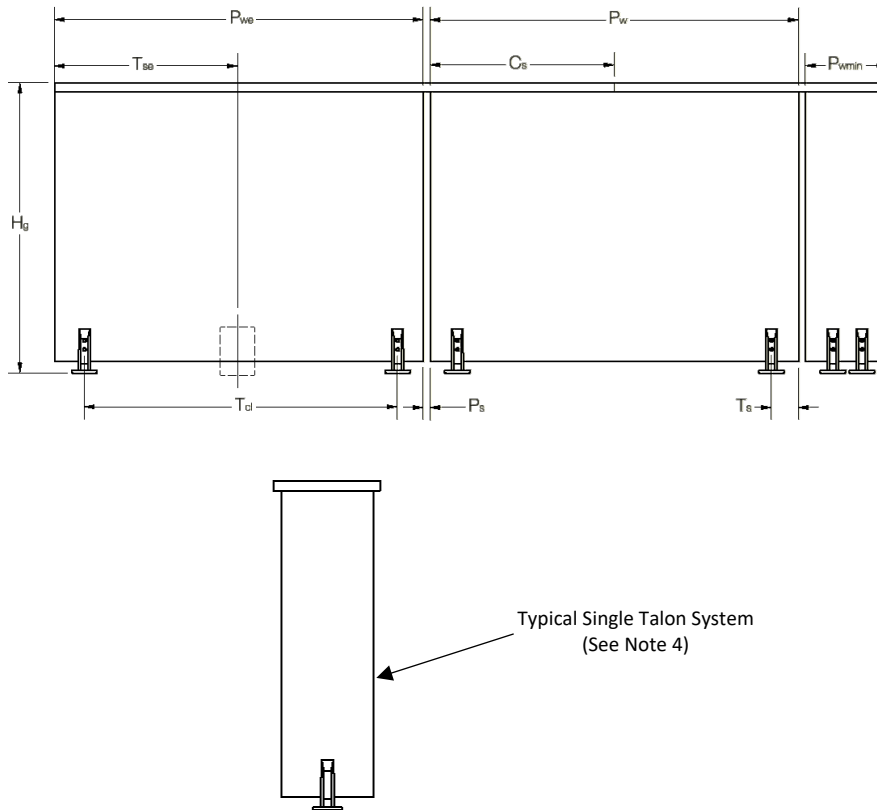

			1/2-inch Monolithic Glass	1/2-inch Laminate Glass ⁷
H _g	Guard Height	H _{gmax}	Maximum Guard Height	42"
		H _{gmin} ⁴	Minimum Guard Height	12"
P _w	Glass Panel Width	P _{wmax}	Maximum Glass Panel Width	54"
		P _{wmin} ⁶	Minimum Glass Panel Width	12"
P _{we} ¹	End Glass Panel Width	P _{wemax} ^{1,2}	Maximum End Glass Panel Width	48"
		P _{wemin} ^{4,5,6}	Minimum End Glass Panel Width	P _{wmin}
P _s	Spacing Between Glass Panels	P _{smax}	Maximum Spacing Between Glass Panels	1"
		P _{smin}	Minimum Spacing Between Glass Panels	0.25"
T _s	Talon Centerline to Glass Panel Edge			4"
T _{cl}	Talon Spacing (Centerline)			P _w - 2T _s
C _s ⁶	Top Rail Coupler Spacing			0.5P _w
T _{se} ²	End Panel 3 rd Talon Centerline to Glass Panel Edge			0.5P _{we}
T _x ⁵	Minimum Number of Talons Per Panel			2

For SI: 1 inch = 25.4 mm

¹ If top rail is adequately supported by post or wall on end, P_{wemax} can be increased to P_{wmax}.
² A 3rd talon must be added on end panels with a width of 42" to 48" when the top rail is not adequately supported.
³ Installation must also comply with Table 4.
⁴ Single panel laminate glass panel minimum width may be reduced to 12" supported by two talons if top rail is adequately supported by a wall or post on both ends.
⁵ Glass panel width between 4" and 12" allowed when supported by a single talon and top rail is adequately supported by a wall or post on both ends.
⁶ Use of top rail coupler on end panels is not permitted unless end of top rail is supported adequately by a wall or post.
⁷ Laminate glass with a .035 inch (0.89 mm) interlayer is required.

FIGURE 10—TALON ASSEMBLY (IRC)³

TABLE 5—ALLOWABLE DIMENSIONS AND WIND LOADS FOR UNIVERSAL STANDOFF PIN SYSTEM (IRC ONLY)^{1,2,3,7}

MAXIMUM MIDDLE GLASS PANEL WIDTH (in.)	MAXIMUM END GLASS PANEL WIDTH (in.)	MAXIMUM GUARD HEIGHT (H _p), in. ^{4,5}	ALLOWABLE WIND PRESSURE (w _{all wind} ⁶), psf
54	As noted in Figures 12-14	49	20
		46	23
		43	25

For SI: 1 inch = 25.4 mm; 1 psf = 47.9 Pa

1. A top rail must be installed in all situations.
2. The top rail must be adequately supported by a wall or post on both ends except when allowed as noted in Figure 13.
3. Standoff pins must be spaced as shown in Figure 12, 13 or 14, as applicable for the selected configuration.
4. Guard height above centerline of top row of standoff pins, H_p.
5. Based on an allowable live load edge stress of 6000 psi, and an allowable deflection of 1-inch when a 200 lb concentrated live load or 50lb concentrated live load are considered in accordance with Section R301.5 of the IRC.
6. w_{all wind} is based on an allowable wind load edge stress of 10600 psi and allowable wind load surface stress of 13500 psi.
7. ½-inch thick nominal monolithic glass complying with section 3.1.2.1 or ½-inch thick nominal laminated glass with a .035-inch (0.89 mm) thick interlayer complying with Section 3.1.2.2 must be used. See Figures 12, 13 or 14 for glass panel dimension requirements, as applicable for the selected configuration.

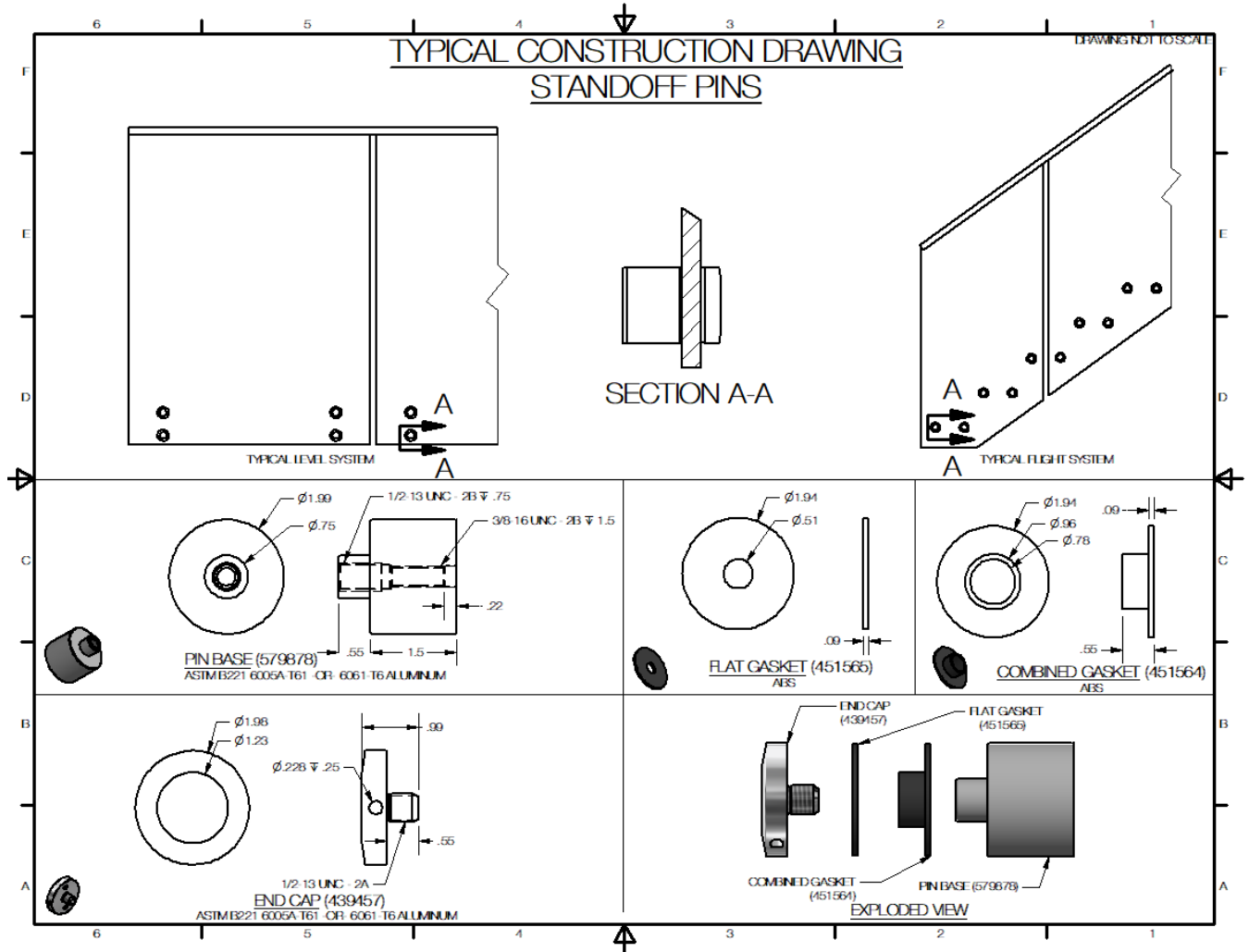
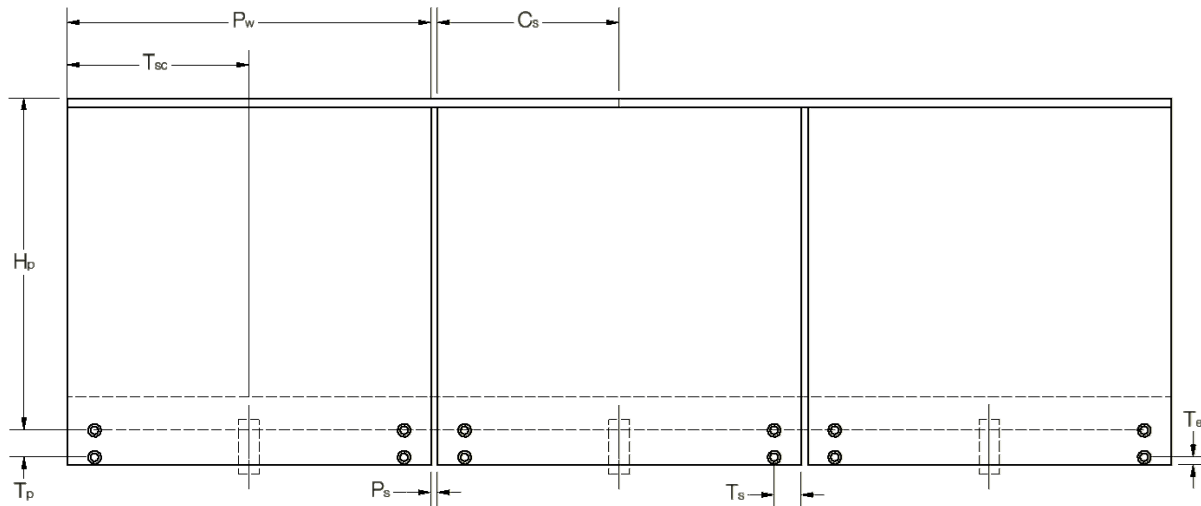

FIGURE 11 – UNIVERSAL STANDOFF PIN SYSTEM



			½-inch Monolithic Glass	½-inch Laminate Glass ⁴
Hp	Guard Height	H _{pmax}	Maximum Guard Height	49"
		H _{pmin}	Minimum Guard Height	19"
P _w	Glass Panel Width	P _{wmax} ¹	Maximum Glass Panel Width	54"
		P _{wmin}	Minimum Glass Panel Width	24"
C _s	Top Rail Coupler Spacing		0.5P _w	0.5 P _w
P _s	Spacing Between Glass Panels	P _{smax}	Maximum Spacing Between Glass Panels	1"
		P _{smin}	Minimum Spacing Between Glass Panels	0.25"
T _s	Universal Standoff Pin Centerline to Glass Panel Edge		6"	6"
T _{sc} ¹	3 rd Standoff Pin Centerline to Glass Panel Edge		0.5P _w	0.5P _w
T _p	Universal Standoff Pin Vertical Centerline to Centerline Spacing	T _{pmax}	Maximum Centerline Spacing	6"
		T _{pmin}	Minimum Centerline Spacing	4"
T _e	Minimum Universal Standoff Pin Minimum Centerline to Glass Panel Edge (Bottom)		1.625"	1.625"

For SI: 1 inch = 25.4 mm

¹ Two sets of standoff pins are required for each panel when the panel width is 42" or less. A 3rd set of standoff pins must be added on panels with a width greater than 42" up to 54".

² Installation must also comply with Table 5.

³ Top rail must be supported adequately by a wall or post on both ends.

⁴ Laminate glass with a .035 inch (0.89 mm) interlayer is required.

FIGURE 12 – UNIVERSAL STANDOFF PIN ASSEMBLY FOR LEVEL RAILINGS / GUARDS (IRC ONLY)^{2,3}

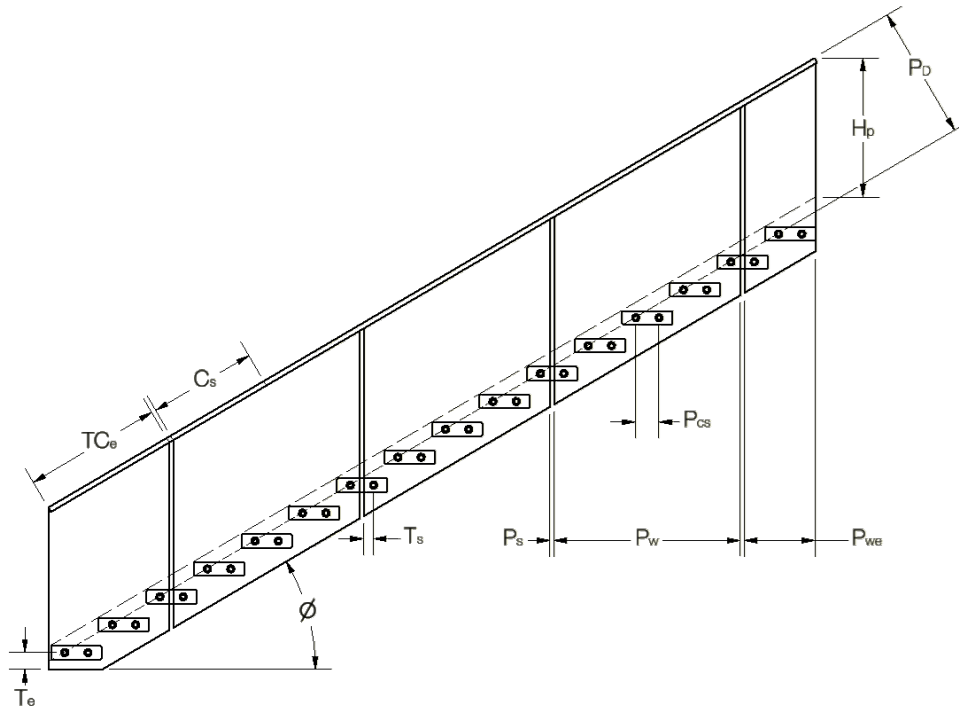

			1/2-inch Monolithic Glass	1/2-inch Laminate Glass ³
H _p	Guard/Handrail Height	H _{pmax}	Maximum Guard/Handrail Height	36"
		H _{pmin}	Minimum Guard/Handrail Height	34"
P _w	Glass Panel Width	P _{wmax}	Maximum Glass Panel Width	54"
		P _{wmin}	Minimum Glass Panel Width	24"
P _{we}	End Glass Panel Width	P _{wemax}	Maximum End Glass Panel Width	54"
		P _{wemin}	Minimum End Glass Panel Width	24"
C _s	Top Rail Coupler Spacing ¹		0.5P _w	0.5P _w
P _D	Maximum Pin Centerline to Top Railing Spacing		35.4"	35.4"
P _s	Spacing Between Glass Panels	P _{smax}	Maximum Spacing Between Glass Panels	1"
		P _{smin}	Minimum Spacing Between Glass Panels	0.25"
∅	Angle of Stair System	∅ _{min}	Minimum Angle	27.5°
		∅ _{max}	Maximum Angle	44.5°
T _s	Pin Centerline to Glass Panel Edge	T _{smax}	Maximum Pin Centerline to Glass Edge	6"
		T _{smin}	Minimum Pin Centerline to Glass Edge	2.5"
T _e	Minimum Universal Standoff Pin Minimum Centerline to Glass Panel Edge (Bottom)		1.625"	1.625"
P _{cs}	Nominal Pin Center to Center Spacing with Respect to Tread Centerline		6"	6"
TC _e ⁴	Maximum End Panel Top Cap Distance		48"	48"

For SI: 1 inch = 25.4 mm

¹ Use of top rail coupler on end panels is not permitted unless end of top rail is supported adequately by the structure.

² Installation must also comply with Table 5.

³ Laminate glass with a 0.035 inch (0.89 mm) interlayer is required.

⁴ TC_e may be increased to 54 inches when the top rail is adequately supported by a wall or post. For TC_e of 48 inches or less, the top rail is not required to be supported by a wall or post.

⁵ Use of top rail coupler on end panels is not permitted unless end of top rail is supported adequately by a wall or post.

FIGURE 13 —UNIVERSAL STANDOFF PIN ASSEMBLY FOR FLIGHT SYSTEM INSTALLATION (IRC ONLY)²

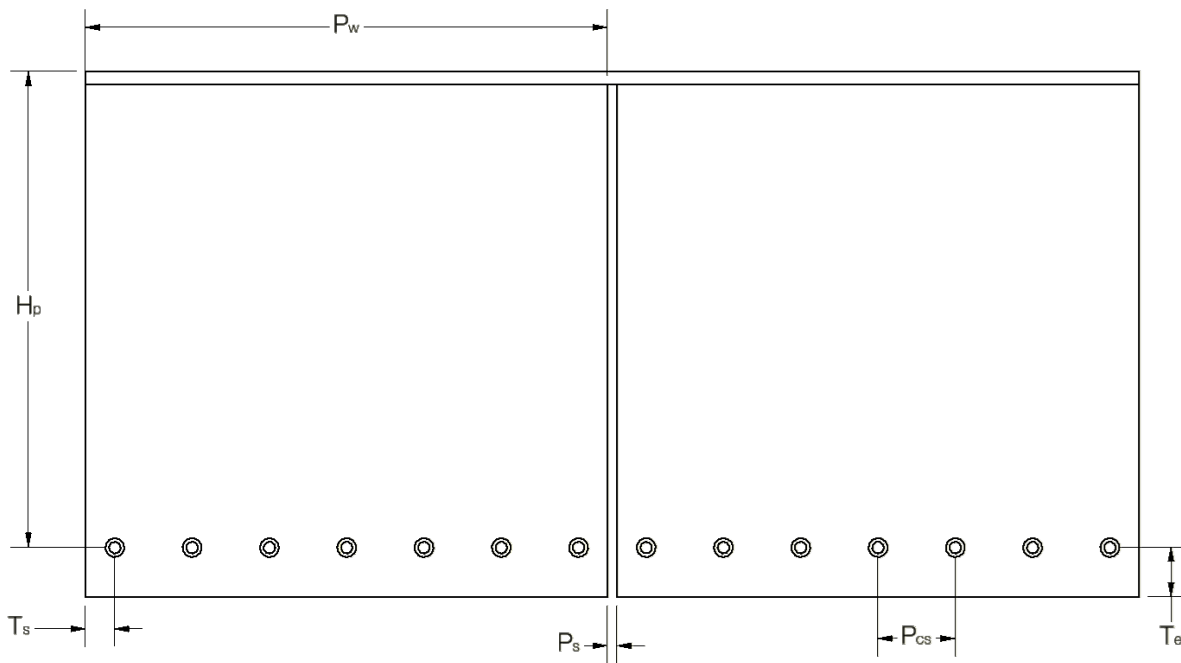

			1/2-inch Monolithic Glass	1/2-inch Laminate Glass ⁵
H_p	Guard/Handrail Height	H_{pmax}	Maximum Guard/Handrail Height	49"
		H_{pmin}	Minimum Guard/Handrail Height	19"
P_w	Glass Panel Width	P_{wmax}	Maximum Glass Panel Width	54"
		P_{wmin}	Minimum Glass Panel Width	24"
T_s	Centerline to Glass Panel Edge	T_{smax}	Maximum Centerline to Glass Panel Edge	6"
		T_{smin}	Minimum Centerline to Glass Panel Edge	2.5"
T_e	Minimum Universal Standoff Pin Minimum Centerline to Glass Panel Edge (Bottom)		1.625"	1.625"
P_{cs}	Horizontal Pin Spacing	P_{csmax}	Maximum Horizontal Pin Spacing	8.167"
		P_{csmin}	Minimum Horizontal Pin Spacing	6"
P_s	Spacing Between Glass Panels	P_{smax}	Maximum Spacing Between Glass Panels	1"
		P_{smin}	Minimum Spacing Between Glass Panels	0.25"

For SI: 1 inch = 25.4 mm

¹ Installation must also comply with Table 5.

² Use of top rail coupler not permitted.

³ Top rail must be adequately supported by a wall or post at both ends.

⁴ Maximum of two glass panels between supported ends of top rail/handrail.

⁵ Laminate glass with a 0.035 inch (0.89 mm) interlayer is required

FIGURE 14 – STANDOFF PIN CONFIGURATION FOR SINGLE ROW INSTALLATION (IRC ONLY)^{1,2,3,4}

DIVISION: 05 00 00—METALS

Section: 05 52 00—Metal Railings

Section: 05 73 13—Glazed Decorative Metal Railings

DIVISION: 08 00 00—OPENINGS

Section: 08 81 00—Glass Glazing

Section: 08 88 00—Special Function Glazing

REPORT HOLDER:

IRON BALUSTER (DBA VIEWRAIL, DBA STAIRSUPPLIES)

EVALUATION SUBJECT:

BASE RAIL, TALON AND UNIVERSAL GLASS PIN GUARDRAIL SYSTEMS

1.0 REPORT PURPOSE AND SCOPE

Purpose:

The purpose of this evaluation report supplement is to indicate that the Base Rail, Talon and Universal Standoff Pin guardrail systems, described in ICC-ES evaluation report [ESR-4799](#), have also been evaluated for compliance with the codes noted below as adopted by the Los Angeles Department of Building and Safety (LADBS).

Applicable code editions:

- 2023 *City of Los Angeles Building Code* (LABC)
- 2023 *City of Los Angeles Residential Code* (LARC)

2.0 CONCLUSIONS

2.1 LABC: The Base Rail and Talon guardrail systems, described in Sections 2.0 through 7.0 of the evaluation report [ESR-4799](#), comply with the LABC Chapter 24, and are subject to the conditions of use described in this supplement.

2.2 LARC: The Base Rail, Talon and Universal Standoff Pin guardrail systems, described in Sections 2.0 through 7.0 of the evaluation report [ESR-4799](#), comply with the LARC, and are subject to the conditions of use described in this supplement.

3.0 CONDITIONS OF USE

The Base Rail, Talon and Universal Standoff Pin guardrail systems described in this evaluation report supplement must comply with all of the following conditions:

- All applicable sections in the evaluation report [ESR-4799](#).
- For use under the LABC, the design, installation, conditions of use and identification of the Base Rail and Talon guardrail systems are in accordance with the 2021 *International Building Code*® (IBC) provisions noted in the evaluation report [ESR-4799](#).
- The design, installation and inspection are in accordance with additional requirements of LABC Chapters 16 and 17, as applicable.
- Under the LARC, an engineered design in accordance with LARC Section R301.1.3 must be submitted.
- The Universal Standoff Pin guardrail system is limited to installations governed by the LARC.

This supplement expires concurrently with the evaluation report, reissued December 2022 and revised March 2024.

DIVISION: 05 00 00—METALS

Section: 05 52 00—Metal Railings

Section: 05 73 13—Glazed Decorative Metal Railings

DIVISION: 08 00 00—OPENINGS

Section: 08 81 00—Glass Glazing

Section: 08 88 00—Special Function Glazing

REPORT HOLDER:

IRON BALUSTER (DBA VIEWRAIL, DBA STAIRSUPPLIES)

EVALUATION SUBJECT:

BASE RAIL, TALON AND UNIVERSAL GLASS PIN GUARDRAIL SYSTEMS

1.0 REPORT PURPOSE AND SCOPE**Purpose:**

The purpose of this evaluation report supplement is to indicate that Base Rail, Talon and Universal Standoff Pin guardrail systems, described in ICC-ES evaluation report ESR-4799, have also been evaluated for compliance with the codes noted below.

Applicable code edition(s):

- 2022 California Building Code (CBC)

For evaluation of applicable chapters adopted by the California Office of Statewide Health Planning and Development (OSHPD) AKA: California Department of Health Care Access and Information (HCAI) and the Division of State Architect (DSA), see Sections 2.1.1 and 2.1.2 below.

- 2022 California Residential Code (CRC)

2.0 CONCLUSIONS**2.1 CBC:**

The Base Rail and Talon guardrail systems, described in Sections 2.0 through 7.0 of the evaluation report ESR-4799, comply with CBC Chapters 10 and 24, provided the design and installation are in accordance with the 2021 *International Building Code*® (IBC) provisions noted in the evaluation report and the additional requirements of CBC Chapters 10, 16 and 24, as applicable.

2.1.1 OSHPD: The applicable OSHPD Sections of the CBC are beyond the scope of this supplement.

2.1.2 DSA: The applicable DSA Sections of the CBC are beyond the scope of this supplement.

2.2 CRC:

The Base Rail, Talon and Universal Standoff Pin guardrail systems, described in Sections 2.0 through 7.0 of the evaluation report ESR-4799, comply with CRC Chapter 3, provided the design and installation are in accordance with the 2021 *International Residential Code*® (IRC) provisions noted in the evaluation report and the additional requirements of CRC Chapter 3.

This supplement expires concurrently with the evaluation report, reissued December 2022 and revised March 2024.

DIVISION: 05 00 00—METALS

Section: 05 52 00—Metal Railings

Section: 05 73 13—Glazed Decorative Metal Railings

DIVISION: 08 00 00—OPENINGS

Section: 08 81 00—Glass Glazing

Section: 08 88 00—Special Function Glazing

REPORT HOLDER:

IRON BALUSTER (DBA VIEWRAIL, DBA STAIRSUPPLIES)

EVALUATION SUBJECT:

BASE RAIL, TALON AND UNIVERSAL GLASS PIN GUARDRAIL SYSTEMS

1.0 REPORT PURPOSE AND SCOPE**Purpose:**

The purpose of this evaluation report supplement is to indicate that the Base Rail, Talon and Universal Standoff Pin guardrail systems, described in ICC-ES evaluation report [ESR-4799](#), have also been evaluated for compliance with the Chicago Construction Codes (Title 14 of the Chicago Municipal Code) as noted below.

Applicable code edition:2019 *Chicago Building Code* (Title 14B)**2.0 CONCLUSIONS**

The Base Rail, Talon and Universal Standoff Pin guardrail systems, described in Sections 2.0 through 7.0 of the evaluation report [ESR-4799](#), comply with Title 14B, and are subject to the conditions of use described in this supplement.

3.0 CONDITIONS OF USE

The Base Rail, Talon and Universal Standoff Pin guardrail systems described in this evaluation report supplement must comply with all of the following conditions:

- All applicable sections in the evaluation report [ESR-4799](#).
- The design, installation, conditions of use and identification of the glass panels must be in accordance with the 2018 *International Building Code*® (IBC) provisions noted in the evaluation report [ESR-4799](#).
- The Universal Standoff Pin guardrail systems are limited to use in Group R-5 occupancies and within individual dwelling units as outlined in Exception 1 of CBC Title 14B Section 1607.8.1.
- The design, installation and inspection must be in accordance with additional requirements of Chapters 16 and 17 of Title 14B, as applicable.
- Installation of the assemblies with monolithic glass are restricted to locations in which there is no walking surface beneath them or locations in which the walking surface is permanently protected from the risk of falling glass as outlined in Section 2407.1 of the CBC.

This supplement expires concurrently with the evaluation report, reissued December 2022 and revised March 2024.

DIVISION: 05 00 00—METALS

Section: 05 52 00—Metal Railings

Section: 05 73 13—Glazed Decorative Metal Railings

DIVISION: 08 00 00—OPENINGS

Section: 08 81 00—Glass Glazing

Section: 08 88 00—Special Function Glazing

REPORT HOLDER:

IRON BALUSTER (DBA VIEWRAIL, DBA STAIRSUPPLIES)

EVALUATION SUBJECT:

BASE RAIL, TALON AND UNIVERSAL GLASS PIN GUARDRAIL SYSTEMS

1.0 REPORT PURPOSE AND SCOPE

Purpose:

The purpose of this evaluation report supplement is to indicate that the Base Rail, Talon and Universal Standoff Pin guardrail systems, described in ICC-ES evaluation report ESR-4799, have also been evaluated for compliance with the codes noted below.

Applicable code editions:

- 2023 Florida Building Code—Building
- 2023 Florida Building Code—Residential

2.0 CONCLUSIONS

The Base Rail, Talon and Universal Standoff Pin guardrail systems, described in Sections 2.0 through 7.0 of ICC-ES evaluation report ESR-4799, comply with the 2023 Florida Building Code—Building and the 2023 Florida Building Code—Residential. The design requirements must be determined in accordance with the Florida Building Code—Building or the Florida Building Code—Residential, as applicable. The installation requirements noted in ICC-ES evaluation report ESR-4799 for the 2021 International Building Code® and the 2021 International Residential Code® meet the requirements of the Florida Building Code—Building or the Florida Building Code—Residential, as applicable, with the following conditions:

1. The Universal Standoff Pin guardrail systems are limited to installations governed by the Florida Building Code—Residential.

Use of the ½" Base Rail, Talon and Universal Standoff Pin guardrail systems for compliance with the High-Velocity Hurricane Zone provisions of the Florida Building Code—Building or the Florida Building Code—Residential has not been evaluated and is outside the scope of this supplemental report.

Use of the ¾" Base Rail has been found to be non-compliance with the High-Velocity Hurricane Zone provisions of the Florida Building Code—Building or the Florida Building Code—Residential. Installation must be in accordance with the Wind-Borne Debris Region requirements noted in ICC-ES evaluation report ESR-4799.

For products falling under Florida Rule 61G20-3, verification that the report holder's quality assurance program is audited by a quality assurance entity approved by the Florida Building Commission for the type of inspections being conducted is the responsibility of an approved validation entity (or the code official when the report holder does not possess an approval by the Commission).

This supplement expires concurrently with the evaluation report, reissued December 2022, revised March 2024.