



● Compliance to International Codes  
● Compliance to State/Regional Codes

## ICC-ES Evaluation Report ESR-4798

Reissued January 2023

This report is subject to renewal January 2025.

**DIVISION: 05 00 00—METALS**  
**Section: 05 52 00—Metal Railings**

### REPORT HOLDER:

**IRON BALUSTER (DBA VIEWRAIL, DBA STAIR SUPPLIES)**

### EVALUATION SUBJECT:

**EXPRESS AND SIGNATURE ALUMINUM RAILING SYSTEMS**

### 1.0 EVALUATION SCOPE

#### Compliance with the following code:

2021, 2018 and 2015 *International Residential Code*® (IRC)

For evaluation for compliance with codes adopted by Los Angeles Department of Building and Safety (LADBS), see [ESR-4798 LARC Supplement](#).

#### Properties evaluated:

- Structural
- Durability

### 2.0 USES

The Express and Signature Aluminum Railing Systems described in this report have been evaluated for use in exterior or interior applications for use as a guard and / or handrail system for balconies, porches, decks and stairs in one- and two-family dwellings constructed in accordance with the IRC. The systems described in this report may also be used in wind-borne debris regions under the IRC.

### 3.0 DESCRIPTION

**3.1 General:** The Express and Signature Aluminum Railing Systems are railing systems consisting of posts, top rails and either cable, rod or glass infill. The systems are available in standard heights of 36, 39 or 42 inches (914, 991 or 1077 mm); see Figure 1. Post heights are available in incremental heights up to 42 inches (1077 mm). Posts and top rails are available with a powder coated finish.

### 3.2 Material:

**3.2.1 Posts:** The Express Posts (Angle End, Angle Line, Level End, Level Line) and Signature Universal Top Posts are comprised of three components: the post mount connection type, the post body, and the post cap. The holes for the rod and cable infill for the Angle End and Angle line posts are off-set for stair applications; the holes for the Level End and Level Line posts are parallel to each other for installation on flat surfaces. See Figure 10.

**3.2.1.1 Post Mount Connection Types:** Posts are available with several connection types: surface mount, side mount, slim side mount, tread mount, and core mount.

**3.2.1.1.1 Surface Mount:** The post foot is welded to the post body. The standard post foot, or base plate, is 3.75 inches (95.3 mm) x 3.75 inches (95.3 mm) x 0.38 inch (9.65 mm) thick and manufactured from ASTM B209 6061-T6 aluminum. The special application post foot is 4.5 inches (114.3 mm) x 4.5 inches (114.3 mm) x 0.38 inch (9.65 mm) thick and manufactured from ASTM B209 6061-T6 aluminum. See Figure 2.

**3.2.1.1.2 Side Mount:** The side mount plate is bolted to the post body. The side mount plate is 6.0 inches (152.4 mm) wide x 6.0 inches (152.4 mm) tall x 0.375 inch (9.5 mm) thick ASTM B209 6061-T6 aluminum. See Figure 2.

**3.2.1.1.3 Slim Side Mount:** The slim side mount system is composed of two mating pieces, a male dovetail mount bolted to the post body and a female receiving mount secured to the structure. The 6 inch (152.4 mm) tall x 2 inch (50.8 mm) wide x 0.3 inch (7.62 mm) thick male slim side mount interface is machined from ASTM B221 6005A-T61 or 6061-T6 aluminum. The 6 inch (152.4 mm) tall x 2 inch (50.8 mm) wide x 0.6 inch (15.2 mm) thick female slim side mount interface is machined from ASTM B221 6005A-T61 or 6061-T6 aluminum. See Figure 3.

**3.2.1.1.4 Core Mount:** The core mount system relies on encapsulating the post body into the supporting structure. See Figure 3.

**3.2.1.1.5 Tread Mount:** The tread mount system consists of a doubler plate mounted inside of the post body. The 2.88 inch (73.1 mm) tall x 1.69 inch wide (42.9 mm) x 3/16 inch (4.76 mm) thick doubler is manufactured from

ASTM A240 304 stainless steel. The post can be secured to stair treads or other flat surfaces. See Figure 3.

**3.2.1.2 Post Body:** The post body is 2 inches (50.8 mm) x 2 inches (50.8mm) x 0.15 inch (3.81 mm) thick ASTM B221 6061-T6 or 6005A-T61 aluminum tube. The hole layout in the post body accommodates the attachment of the cable, rod or glass infill components. For cable or rod infill, the holes are spaced 3.125 inches (79 mm) on center to provide an opening of less than 4 inches (102 mm) in accordance with IRC Section R312.1.3 See Figure 1. For glass infill, the bottom hole is spaced 7 inches (178 mm) from the walking surface, and the top hole is spaced 7-1/2 (191 mm) inches from the bottom of the handrail. The holes are factory tapped with 5/16-18 threads to accommodate the attachment of the glass infill hardware.

**3.2.1.3 Post Cap:** The post cap is press-fit into the post body. Three post top configurations are available: universal, standard flat top, and Quick Slide flat top. The post cap is manufactured to the dimensions shown in Figure 4 from ASTM B221 6061-T6 or 6005A-T61 aluminum.

### 3.2.2 Top Rails:

**3.2.2.1 Rectangular:** Rectangular top rails are manufactured from ASTM B221 6061-T6 or 6005A-T61 aluminum. The rectangular top rails are 0.125 inch thick extrusions that measure either 2 inches (50.8 mm) x 1 inch (25.4 mm) or 4 inches (101.6 mm) x 1 inch (25.4 mm). The 2 inches (50.8 mm) x 1 inch (25.4 mm) rectangular top rail meets the graspability requirements for a Type I handrail as outlined in IRC Section R311.7.8.5. The 4 inches (101.6 mm) x 1 inch (25.4 mm) rectangular top rail does not meet the graspability requirements outlined in IRC Section R311.7.8.5, and installations must be limited to locations in which the system is used as a guard only. See Figure 5.

**3.2.2.2 Quick Slide:** Quick Slide top rails are manufactured from ASTM B221 6061-T6 or 6005A-T61 aluminum. The Quick Slide top rails measure 2 inches (50.8 mm) x 1 inch (25.4 mm) or 4 inches (101.6 mm) x 1 inch (25.4 mm) and have an extruded slot profile used for attaching the top rail to the universal top rail bracket. The 2 inch (50.8 mm) x 1 inch (25.4 mm) Quick Slide top rail meets the graspability requirements for a Type I handrail as outlined in IRC Section R311.7.8.5. The 4 inch (101.6 mm) x 1 inch (25.4 mm) Quick Slide top rail does not meet the graspability requirements outlined in IRC Section R311.7.8.5, and installations must be limited to locations in which the system is used as a guard only. See Figure 6.

**3.2.2.2.1 Quick Slide Coupler:** The Quick Slide Coupler is used to join sections of Quick Slide top rails and is manufactured from ASTM B221 6061-T6 or 6005A-T61 aluminum. The Quick Slide Couplers measure 1.88 inches (47.8 mm) x 1.07 inch (27.2 mm) x 1.11 inch (28.2 mm).

### 3.2.3 Top Rail Brackets:

**3.2.3.1 Universal:** The universal top rail brackets are used to attach the rectangular top rail profiles to the post caps. The brackets are manufactured from 0.12 inch (3.05 mm) thick ASTM A240 304 stainless steel and are available as a full bracket or half bracket. The full brackets are used for continuous runs of top rail and the half brackets are used at top rail terminations. See Figure 7.

**3.2.3.2 Flat:** The flat top rail brackets are used to attach the rectangular top rail profiles to the post caps. The brackets are manufactured from 0.12 inch (3.05 mm) thick ASTM B221 6005A-T61 or 6061-T6 aluminum and are

available as a full bracket or half bracket. The full brackets are used for continuous runs of top rail and the half brackets are used at top rail terminations. See Figure 7.

**3.2.3.3 Quick Slide Universal:** The Quick Slide top rail brackets are used to attach the Quick Slide top rail profiles to the post caps. The brackets are manufactured from ASTM B221 6061-T6 or 6005A-T61 aluminum. See Figure 8.

**3.2.3.4 Quick Slide Flat:** The Quick Slide flat top rail brackets are used to attach the rectangular Quick Slide top rail profiles to the post caps. The brackets are manufactured from 0.25 inch (6.4 mm) thick ASTM B221 6005A-T61 or 6061-T6 aluminum and are available as a full bracket or half bracket. The full brackets are used for continuous runs of top rail and the half brackets are used at top rail terminations. See Figure 8.

### 3.2.4 Fasteners:

#### 3.2.4.1 Rail Brackets

**3.2.4.1.1 Universal Top Rail Brackets:** ¼-20 x 0.375 inch (6.35 mm) long ASME B18.3 button head screws are used to attach the Universal brackets to the post caps.

**3.2.4.1.2 Flat Top Rail Brackets:** ¼-20 x 0.75 inch (19 mm) long ASME B18.6.3 flat head Phillips screws are used to attach the flat bracket and flat half brackets to the post caps.

**3.2.4.1.3 Quick Slide Rail Brackets:** ¼-20 x 0.5 inch (12.7 mm) long aluminum flat head socket screws machined from ASTM B221 6061-T6 or 6005A-T61 aluminum are used to attach both the Quick Slide Universal and Quick Slide Flat brackets to the post caps.

#### 3.2.4.2 Top Rails:

**3.2.4.2.1 Rectangular Top Rail:** 3/4 inch (19 mm) long #8 self-tapping ASTM A276 410 stainless steel screws are used to attach the rectangular top rails to the universal top brackets.

**3.2.4.2.2 Quick Slide Top Rail:** The Quick Slide top rail is attached to the quick slide handrail bracket with 1.6 inches (40.6 mm) long x 0.44 inch (11.2 mm) wide by 0.18 inch (4.6 mm) thick Quick Slide Nuts machined from ASTM B221 6061-T6 or 6005A-T61 aluminum and two ¼-20 x 0.5 inch (12.7 mm) long flat head screws machined from ASTM B221 6061-T6 or 6005A-T61 aluminum.

#### 3.2.4.3 Side Mount Plates:

**3.2.4.3.1 Side Mount Plate:** The side mount plate is attached to the post with three ½-13 x 0.800 inch (20.3 mm) long low profile socket hex head screws machined from ASTM B221 6061-T6 or 6005A-T61 aluminum and one threaded bracket 4.9 inches (124.5 mm) long x 0.75 inch (19 mm) wide x 0.375 inch (9.5 mm) thick machined from ASTM B221 6061-T6 or 6005A-T61 aluminum.

**3.2.4.3.2 Slim Side Mount Plate:** The male slim side mount is secured to the post tube with two 5/16"-18 x 1 inch (25.4 mm) long ASME B18.3 316 SS flat head cap screws, four nylon washers, and two 5/16"-18 ASTM F594 316 SS flange nuts.

**3.2.4.4 Glass Clips:** The glass clip outer blades are secured to the clip center with two 5/16-18 x 0.47 inch (11.9 mm) low hex head screws machined from ASTM A276 316 stainless steel per blade. The glass clip assembly is secured to the post tube with one 5/16-18 cap head screw machined from ASTM B221 6061-T6 aluminum.

### 3.2.5 Infill:

**3.2.5.1 Cables:** The cables used for the infill are  $\frac{5}{32}$  inch (4 mm) diameter 1 x 19 ASTM A492 316 stainless steel. The cable is available in 100 foot (30.5 m) or 400 foot (122 m) spools.

**3.2.5.2 Rods:** The rods used for the infill are  $\frac{1}{4}$  inch (6.4 mm) diameter ASTM A276 304 or 2205 Duplex Stainless Steel tubing. The rods are available in lengths of 4 feet (1.2 m) to 20 feet (6.1 m).

#### 3.2.5.3 Glass:

**3.2.5.3.1 Monolithic Glass:** The monolithic glass panels must be fully tempered (FT) glass complying with ASTM C1048, ANSI Z97.1 Class A and Category II of CPSC 16 CFR 1201 (procured separately). The glass panels must have a minimum Modulus of Rupture (Fr) of 24,000 psi (165 MPa).

The glass panels must have a nominal thickness of either  $\frac{3}{8}$ -inch (10 mm) or  $\frac{1}{2}$ -inch (12 mm), and the minimum thickness of the glass panels must be at least 0.355-inch (9.02 mm) or 0.469-inch (11.91 mm), respectively.

**3.2.5.3.2 Laminate Glass:** The laminate glass panels must be comply with ASTM C1172, ANSI Z97.1 Class A and Category II of CPSC 16 CFR 1201 (procured separately). The panels must consist of two lites of glass with an interlayer.

**3.2.5.3.3 Lites:** The individual lites must have a nominal thickness of  $\frac{1}{4}$ -inch (6 mm); the minimum thickness of the lites must be 0.219-inch (5.56 mm). The lites must be Kind FT tempered glass complying with ASTM C1048 and must have a minimum Modulus of Rupture (Fr)  $\geq$  24,000 psi (165 Mpa).

**3.2.5.3.4 Interlayer:** The interlayer must be a non-PVB type interlayer with a minimum thickness of either 0.035-inch (0.89 mm) or 0.060-inch (1.52 mm). The interlayer must have a minimum shear modulus of 3,828 psi (26.4 MPa) for  $T \leq 122^\circ\text{F}$  ( $50^\circ\text{C}$ ).

### 3.2.6 Infill Hardware:

**3.2.6.1 Cable Railing Hardware:** The hardware used to attach the cable railing infill to the posts consists of threaded crimp fittings, tension receivers, inside post mount fittings and angle washers. All of the cable railing assembly hardware is manufactured from ASTM A276 316 stainless steel. See Figure 10.

**3.2.6.2 Rod Railing Hardware:** The hardware used to attach the rod railing infill to the posts consists of threaded crimp fittings, tension receivers, level anchors, and angle washers. All of the rod railing assembly hardware is manufactured from ASTM A276 316 stainless steel. See Figure 10.

**3.2.6.3 Glass Infill Hardware:** The glass panels are secured to the post tubes with four glass clip assemblies (two per side). A PETG gasket is placed between the post body and each glass clip assembly. The glass clip assembly consists of two 1.75 inch (44.5 mm) tall x 1.75 inch (44.5 mm) wide x 0.25 inch (6.4 mm) thick blades machined from ASTM A276 316 stainless steel bolted to a 1.75 inch (44.5 mm) tall tapered clip center [sized for the glass panel thickness; either  $\frac{3}{8}$ -inch (9.5 mm) or  $\frac{1}{2}$ -inch (12.7 mm) thick] made from ASTM A276 316 stainless steel. 1.62 inch (41.1 mm) tall x 0.62 (15.7mm) x 0.18 inch (4.6 mm) thick ABS gaskets prevent direct glass to metal contact. See Figure 9.

## 4.0 DESIGN AND INSTALLATION

### 4.1 Design:

**4.1.1 General:** The Express and Signature Aluminum Railing Systems are rated to withstand the loads specified in IRC Table R301.5, when installed at a maximum center to center post spacing of 48 inches (1.22 m) for the cable and rod infill systems and 58 inches (1.47 m) for glass infill systems. For stairs, the Express and Signature Aluminum Railing Systems have also been evaluated for installation on stairs with an incline of 45 degrees or less with the posts horizontally spaced at a maximum of 48 inches (1.22 m) on center.

#### 4.1.2 Glass Infill:

**4.1.2.1 Glass Size:** The glass panel size must conform to the dimensions below. The glass panels must be placed such that there is a 2-inch (50.4 mm) space between the ground surface and the bottom of the glass and a 2-inch (50.4 mm) space between the bottom of the top rail and the top of the glass panel (see Figure 1).

Glass Panel Width = Post Spacing ( $P_s$ ) – 4 inches (102 mm)

Glass Panel Height = Rail Height ( $R_h$ ) – 5 inches (127 mm)

**4.1.2.2 Wind Loads with Glass Infill:** The allowable wind loads on systems utilizing laminate glass infill described in Section 3.2.5.3.2 or monolithic glass infill described in Section 3.2.5.3.1 with a minimum  $\frac{1}{2}$ -inch (12 mm) nominal thickness are shown in Table 1. The allowable loads on systems utilizing monolithic glass infill described in Section 3.2.5.3.1 with a minimum  $\frac{3}{8}$ -inch (10 mm) nominal thickness are shown in Table 2.

### 4.2 Installation:

**4.2.1 General:** Installation must be in accordance with the manufacturer's published installation instructions, this report and the guard height and opening limitations outlined in Section R312 of the IRC. The manufacturer's published installation instructions must be available at the jobsite at all times during construction. All fasteners must be tightened per the manufacturer's installation instructions.

**4.2.2 Posts:** The posts are attached to the building substrate with project specific fasteners or are embedded into concrete. The design of this attachment is outside of the scope of this report.

#### 4.2.3 Top Rail Brackets:

**4.2.3.1 Attachment to Universal Post Cap:** The Universal top rail brackets are attached to the universal post cap using  $\frac{1}{4}$ -20 x 0.375 inch (6.35 mm) long ASME B18.3 button head screws. The Quick Slide top rail brackets are attached using  $\frac{1}{4}$ -20 x 0.5 inch (12.7 mm) long aluminum flat head socket screws machined from ASTM B221 6061-T6 or 6005A-T61 aluminum.

**4.2.3.2 Attachment to Standard Flat Top Post Cap:** The Universal flat brackets are attached to the standard flat top post cap using two  $\frac{1}{4}$ -20 x 0.75 inch (19 mm) long ASME B18.6.3 flat head Phillips screws.

**4.2.3.3 Attachment to Quick Slide Flat Top Post Cap:** The Quick Slide flat brackets are attached to the Quick Slide flat top post cap using  $\frac{1}{4}$ -20 x 0.5 inch (12.7 mm) long aluminum flat head socket screws machined from ASTM B221 6061-T6 or 6005A-T61 aluminum.

#### 4.2.4 Top Rails:

**4.2.4.1 Rectangular Top Rails:** The rectangular top rails are attached to the Universal or flat brackets using 0.75 inch



(19 mm) long #8 self-tapping screws. The rectangular top rails are pre-drilled at the fastener locations using the brackets as a template. Six screws are required for attachment to the full universal bracket, and four screws are required for attachment to the universal half bracket. Six screws are required for the attachment of the full flat bracket and three screws are required for attachment of the half flat bracket. Handrail splices must be centered directly over a post with a full bracket. See Figure 5.

**4.2.4.2 Quick Slide Top Rails:** The Quick Slide top rails are attached to the Quick Slide brackets (standard or flat) by sliding the Quick Slide bracket into the extruded channel of the top rail and subsequently tightening the bracket fasteners. Handrail splices must be located directly over a post using a Quick Slide Coupler. See Figure 6.

#### 4.2.5 Infill:

**4.2.5.1 Cable Infill:** The continuous cables are cut to the appropriate length for the installation. The cables are installed in horizontal runs through the posts. Threaded crimp fittings are attached to each end of the cables according to the manufacturer's instructions with the crimping tool (supplied by the manufacturer). On end posts, tension receivers are inserted into the holes and threaded onto the threaded crimp fitting. Alternatively, an inside post mount can be crimped to one cable end and used to anchor one end of the cable; a crimp fitting and tension receiver is used on the opposite end post. Once all cables have been installed, they are tensioned in sequence per the manufacturer's installation instructions. See Figure 10.

For installations on stairs, the same procedures are followed, except that angle washers are placed between the head of the tension receiver and the outside of the posts. Once all rods have been installed, they are tensioned in sequence per the manufacturer's installation instructions. See Figure 10.

**4.2.5.2 Rod Infill:** The continuous rods are cut to the appropriate length for the installation. The end posts are identified as being either the "anchor post" or the "tension post". Threaded crimp fittings are attached to each end of the threaded rods according to the manufacturer's instructions with the crimping tool (supplied by the manufacturer). The level rod anchor is tapped into the anchor post with a dead-blow hammer. The flanges on the level rod anchor are extended by threading the level rod anchor tool (supplied by the manufacturer) completely into the level rod anchor. The rods are installed in horizontal runs through the posts, and the threaded crimp fitting is fully threaded into the level rod anchor fitting. On the tension post, a tension receiver is inserted into the hole and is threaded onto the threaded crimp fitting. Once all rods have been installed, they are tensioned in sequence per the manufacturer's installation instructions. See Figure 10.

For installations on stairs, the same procedures are followed, except that tension receivers are used on both ends of the rods, and angle washers are placed between the head of the tension receiver and the outside of the posts. Once all rods have been installed, they are tensioned in sequence per the manufacturer's installation instructions. See Figure 10.

**4.2.5.3 Glass Infill:** Either 3/8 inch (10 mm) or 1/2 inch (12 mm) glass panels are installed to the railing system with 2 glass clips per side. The glass clip centers are attached to the post with one 5/16-18 aluminum cap head screw. The glass is clamped in place between the glass blades and glass gaskets by tightening the glass blade screws in

accordance with the manufacturer's installation instructions. See figure 9.

## 5.0 CONDITIONS OF USE

The Express and Signature Aluminum Railing Systems described in this report comply with, or are a suitable alternative to what is specified in, those codes listed in Section 1.0 of this report, subject to the following conditions:

- 5.1 The products are limited to installations where they are not subject to vehicle impacts.
- 5.2 Installation must comply with this report, the manufacturer's published installation instructions and the applicable code. When the manufacturer's published installation instructions differ from this report, this report governs.
- 5.3 The supporting structure and anchorage of the systems to the supporting structure is outside the scope of this report and must be designed by a registered design professional and constructed to support the loads imposed by the systems in accordance with the applicable code.
- 5.4 When installed where the system anchors are exposed to moisture, the system anchors must be of a material intended for the use and identified by the manufacturer as acceptable for exterior applications.
- 5.5 All metals in contact with aluminum must either be an alloy approved for direct aluminum contact, or isolated from the aluminum by an approved coating.
- 5.6 Use of the systems as a grab bar is outside of the scope of this report.
- 5.7 The products have only been evaluated for straight runs of guardrail, and corners are outside of the scope of this report.
- 5.8 Systems utilizing the 1 inch (25.4 mm) x 4 inch (102 mm) rectangular top rails must be limited to installations for use as a guard; use as a handrail is not permitted.

## 6.0 EVIDENCE SUBMITTED

Data in accordance with the ICC-ES Acceptance Criteria for Handrails and Guards (AC273), dated June 2017 (editorially revised May 2021).

## 7.0 IDENTIFICATION

- 7.1 Product labeling shall include, the name of the report holder or listee, and the ICC-ES mark of conformity. The listing or evaluation report number (ICC-ES ESR-4798) may be used in lieu of the mark of conformity. The Express and Signature Aluminum Railing System components described in this report are identified by a label on the packaging bearing the manufacturer's name; product description and/or part number; and the ICC-ES evaluation report number (ESR-4798). The Express and Signature Aluminum Railing Systems must additionally be labeled with the following language, "For Use in One- and Two-Family Dwellings Only."

- 7.2 The report holder's contact information is the following:

**IRON BALUSTER (DBA VIEWRAIL, DBA STAIR SUPPLIES)**

**1722 EISENHOWER DRIVE NORTH**

**GOSHEN INDIANA, 46526**

**1-866-261-8013**

[www.viewrail.com](http://www.viewrail.com)

[www.stairsupplies.com](http://www.stairsupplies.com)

TABLE 1: ALLOWABLE WIND LOADS FOR 1/2-INCH MONOLITHIC AND LAMINATE GLASS INFILL

Allowable Wind Pressure, $W_a$ (psf)		Railing Height $R_h$ (inch)			
		26	36	39	42
Post Spacing $P_s$ (inch)	12	70	70	70	70
	24	70	70	70	70
	36	70	70	59	50
	48	70	51	43	36
	58	70	35	29	25

For SI: 1 psf = 47.88 Pa; 1 inch = 25.4 mm

TABLE 2: ALLOWABLE WIND LOADS FOR 3/8-INCH MONOLITHIC GLASS INFILL

Allowable Wind Pressure, $W_a$ (psf)		Railing Height $R_h$ (inch)			
		26	36	39	42
Post Spacing $P_s$ (inch)	12	49	49	49	49
	24	49	49	49	49
	36	49	49	41	35
	48	49	29	24	21
	58	49	24	20	17

For SI: 1 psf = 47.88 Pa; 1 inch = 25.4 mm

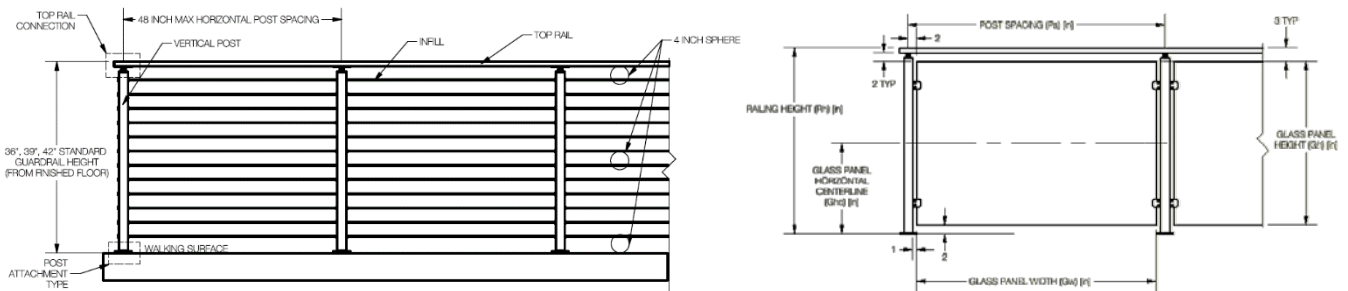

FIGURE 1—TYPICAL CABLE/ROD INFILL ELEVATION VIEW (LEFT) AND GLASS INFILL ELEVATION VIEW (RIGHT)

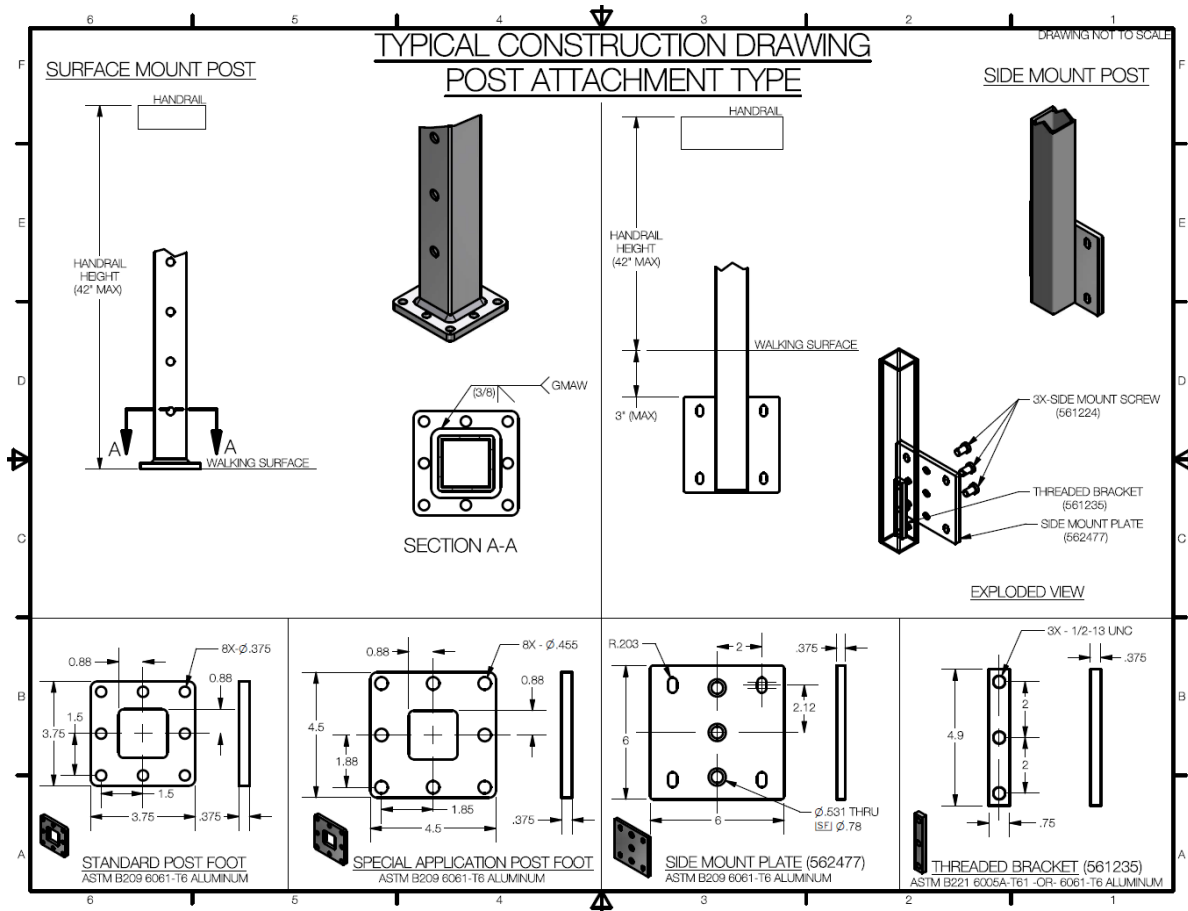

FIGURE 2 – SURFACE AND SIDE MOUNT POST ATTACHMENT TYPE

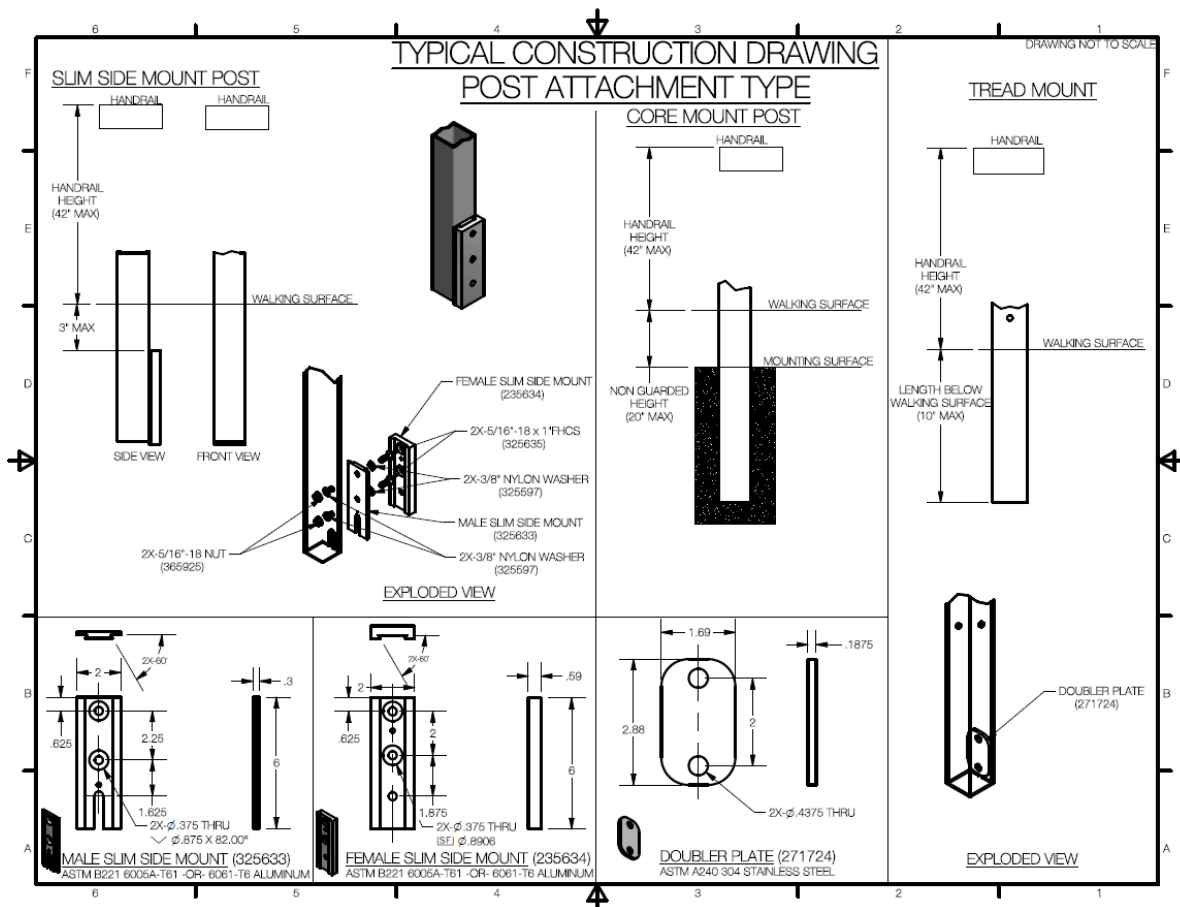

FIGURE 3 – SLIM SIDE MOUNT, CORE MOUNT, AND TREAD MOUNT POST ATTACHMENT TYPE

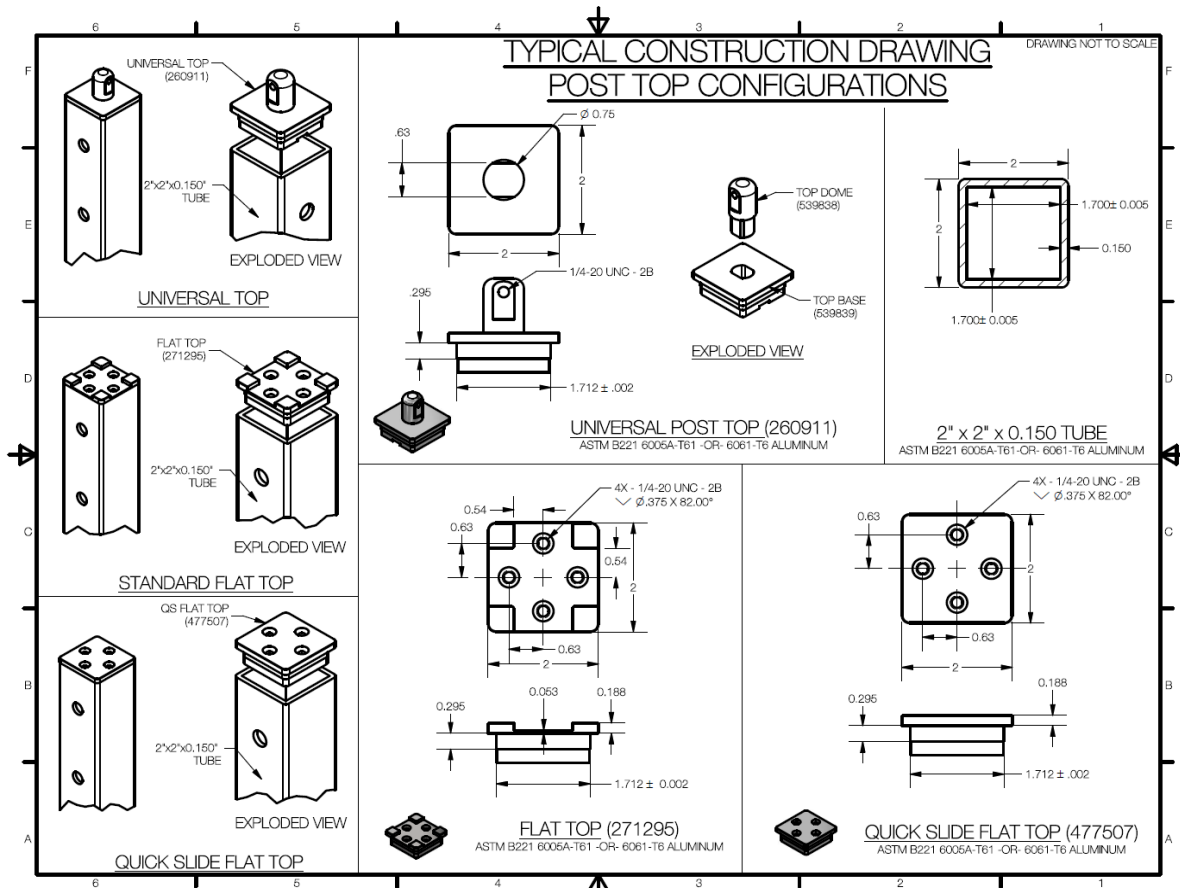

FIGURE 4 – POST TOP CONFIGURATIONS

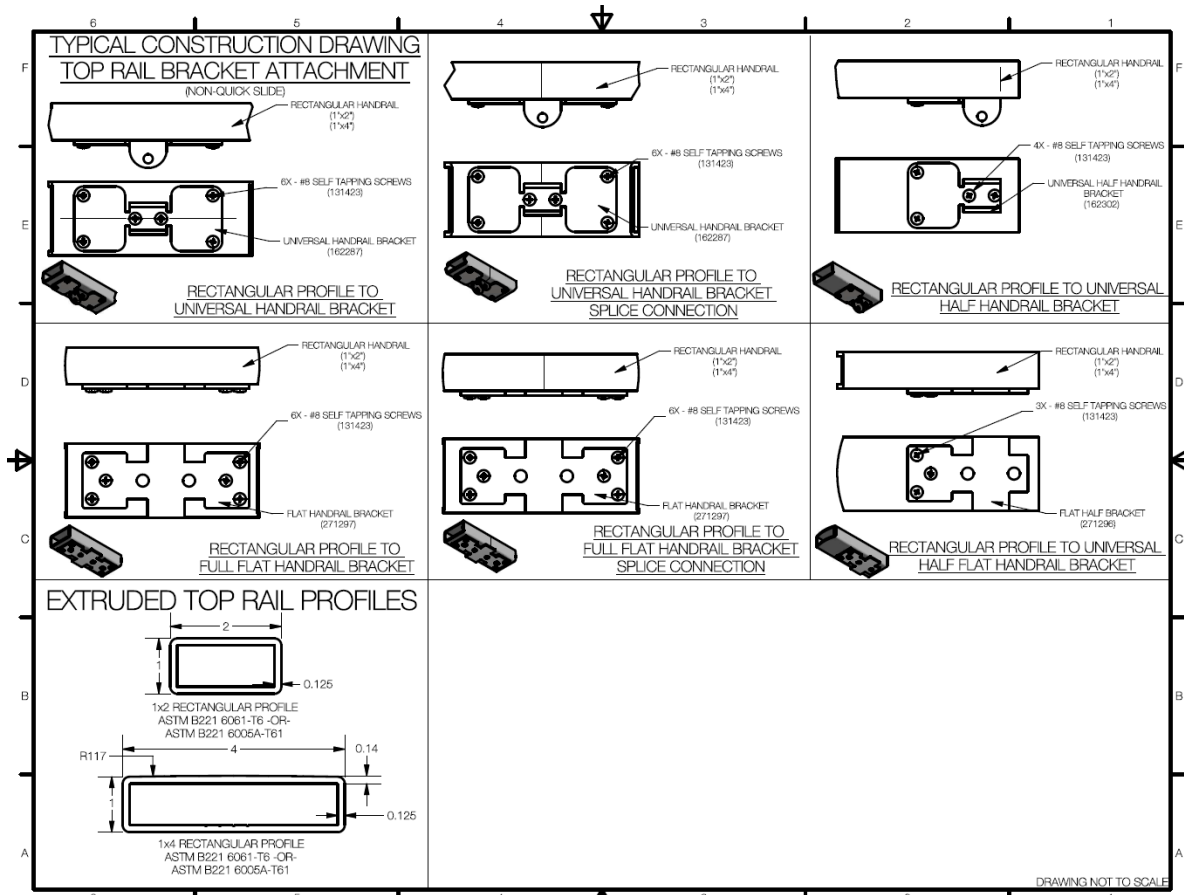

FIGURE 5 – RECTANGULAR TOP RAIL ATTACHMENT DETAIL

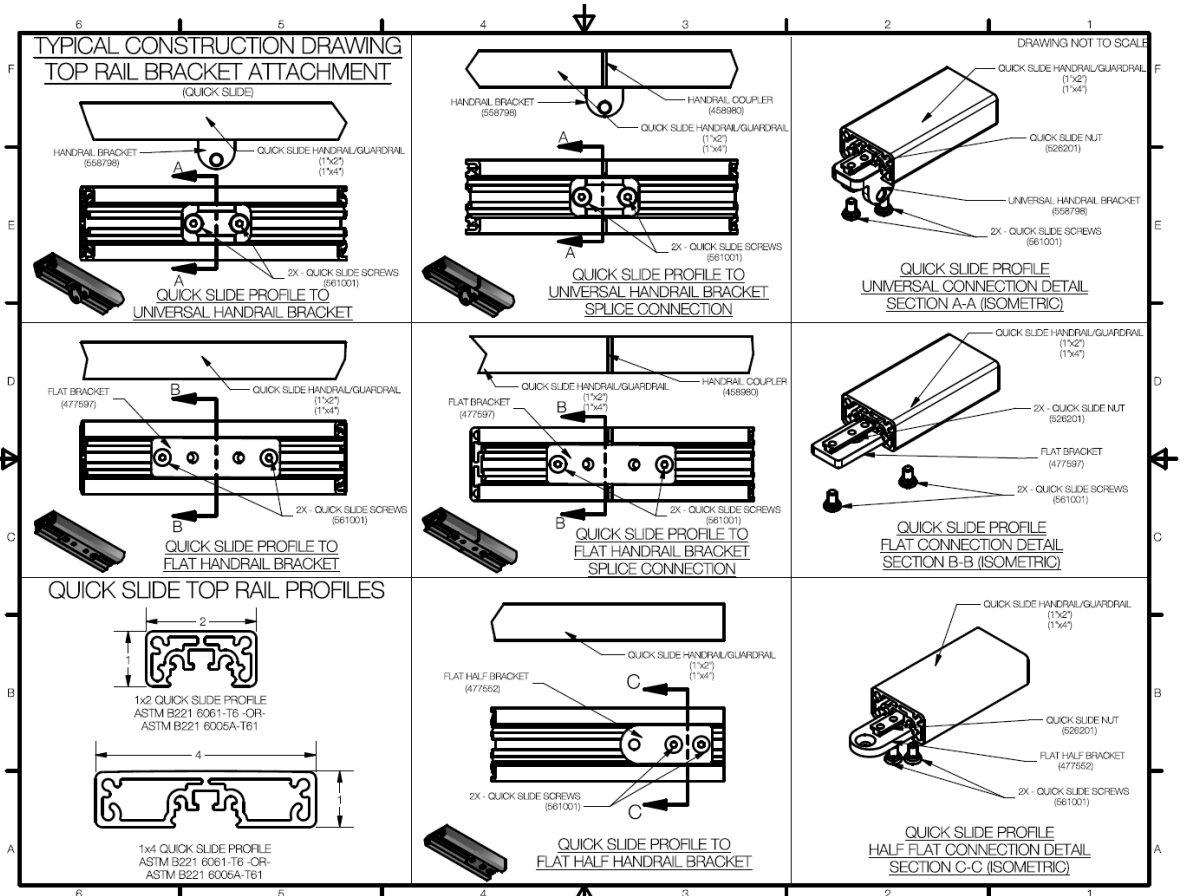

FIGURE 6 – QUICK SLIDE TOP RAIL ATTACHMENT DETAIL

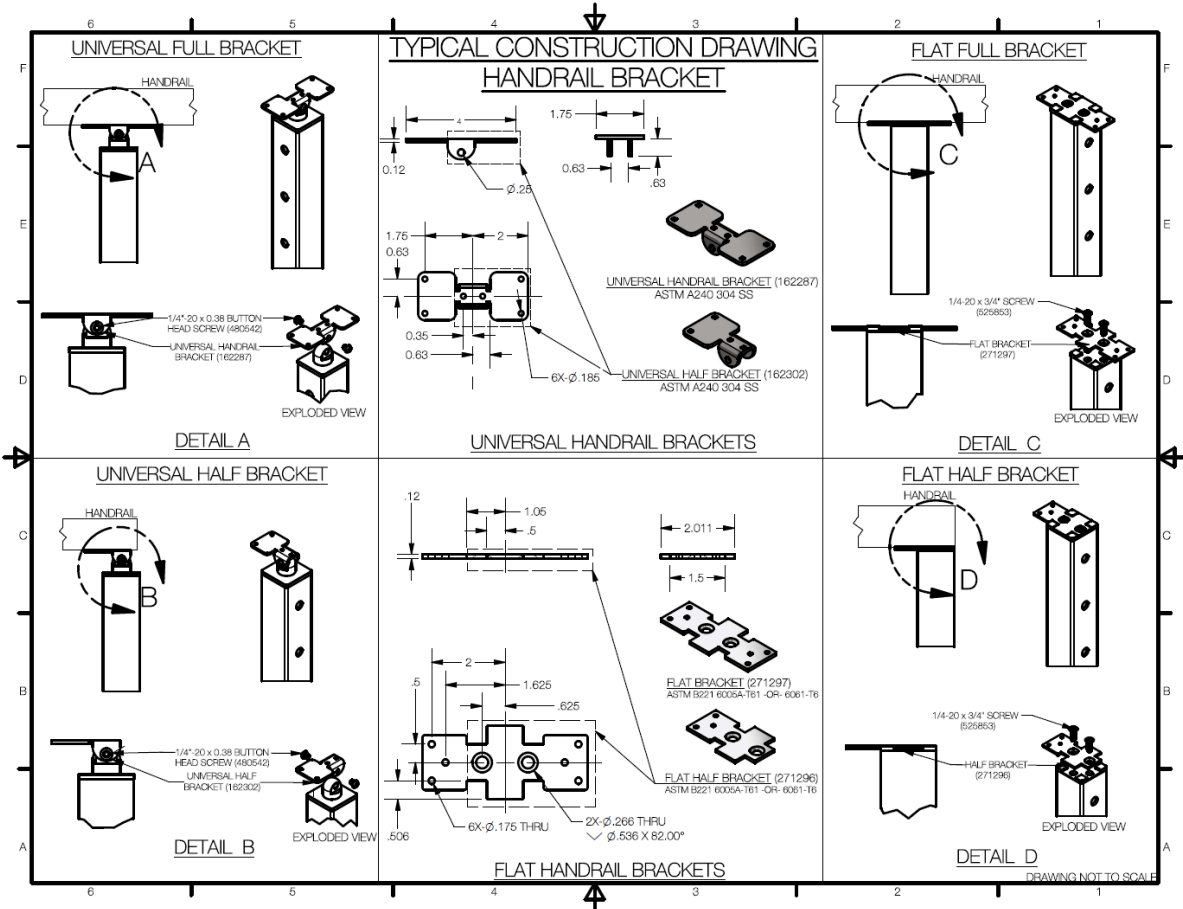

FIGURE 7 – UNIVERSAL AND FLAT HANDRAIL BRACKETS

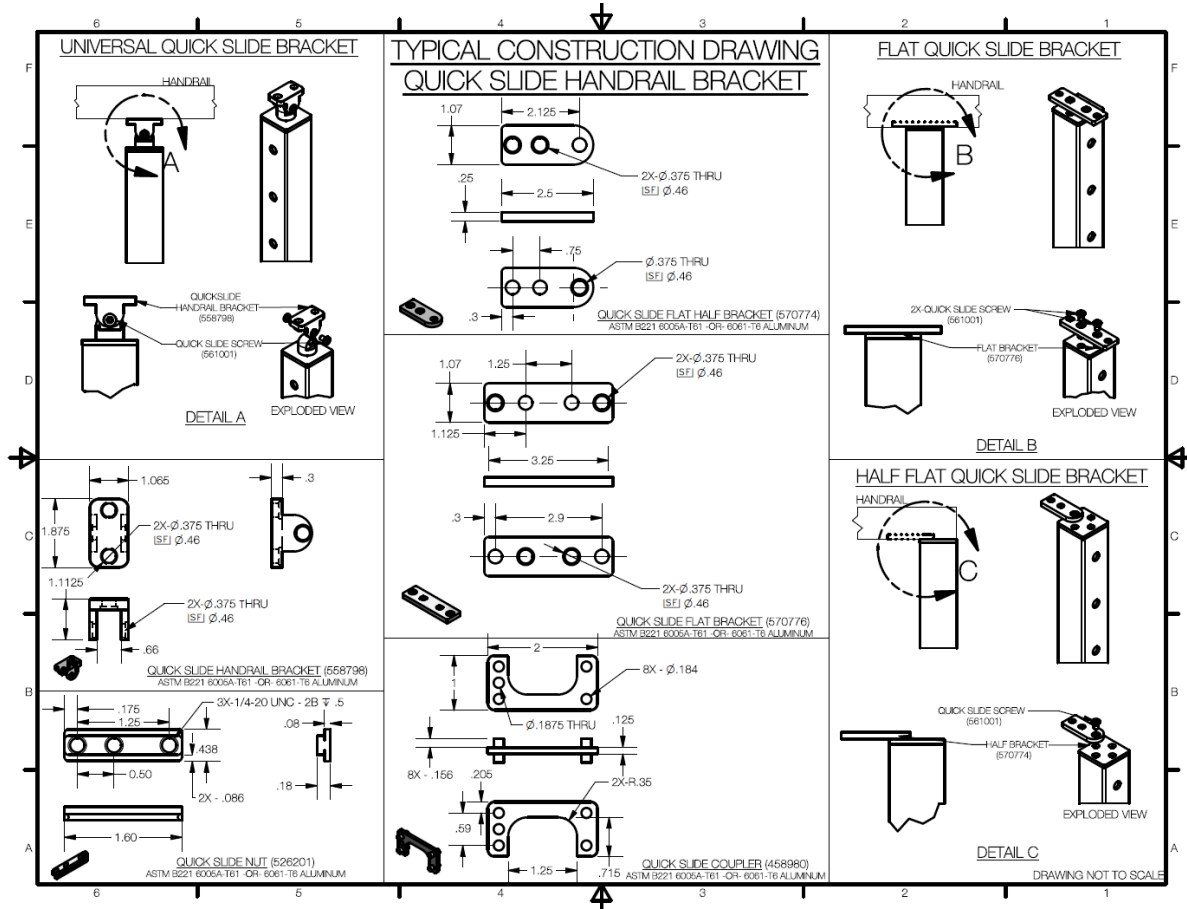

FIGURE 8 – QUICK SLIDE UNIVERSAL AND FLAT HANDRAIL BRACKETS



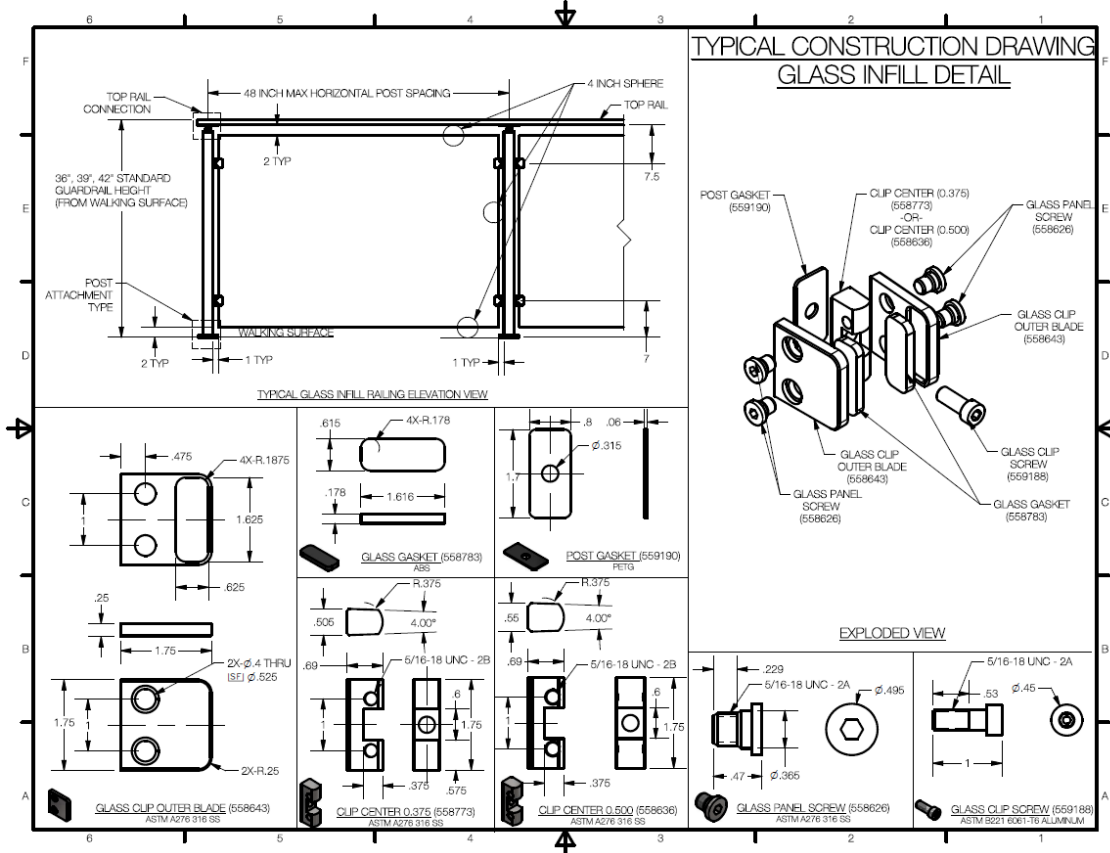

FIGURE 9 – GLASS CLIP INFILL DETAIL

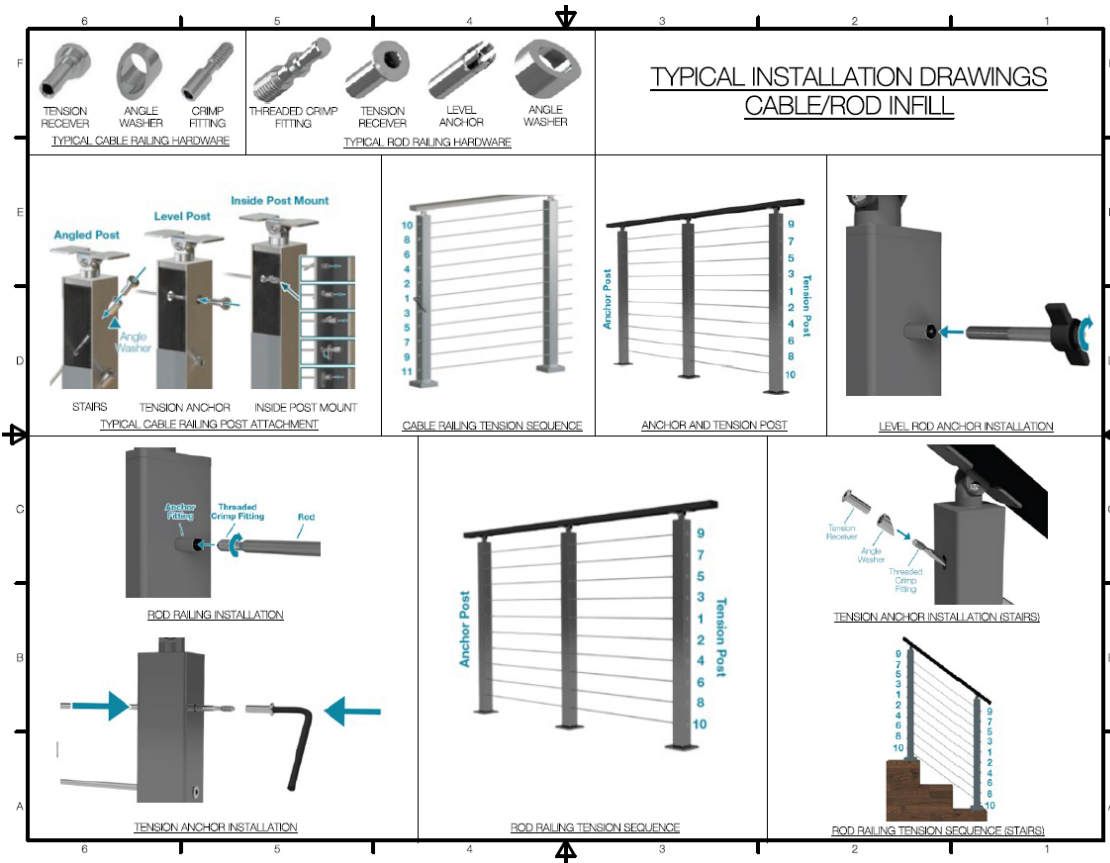

FIGURE 10 – TYPICAL INSTALLATION DRAWINGS CABLE/ROD INFILL

**DIVISION: 05 00 00—METALS**  
**Section: 05 52 00—Metal Railings**

**REPORT HOLDER:**

**IRON BALUSTER (DBA VIEWRAIL, DBA STAIR SUPPLIES)**

**EVALUATION SUBJECT:**

**EXPRESS AND SIGNATURE ALUMINUM RAILING SYSTEMS**

**1.0 REPORT PURPOSE AND SCOPE****Purpose:**

The purpose of this evaluation report supplement is to indicate that the Express and Signature Aluminum Railing Systems, described in ICC-ES evaluation report [ESR-4798](#), have also been evaluated for compliance with the code noted below as adopted by the Los Angeles Department of Building and Safety (LADBS).

**Applicable code edition:**

2020 *City of Los Angeles Residential Code* (LARC)

**2.0 CONCLUSIONS**

The Express and Signature Aluminum Railing Systems, described in Sections 2.0 through 7.0 of the evaluation report [ESR-4798](#), comply with the LARC, and are subject to the conditions of use described in this supplement.

**3.0 CONDITIONS OF USE**

The Express and Signature Aluminum Railing Systems described in this evaluation report supplement must comply with all of the following conditions:

- All applicable sections in the evaluation report [ESR-4798](#).
- The design, installation, conditions of use and identification of the Express and Signature Aluminum Railing Systems are in accordance with the 2018 *International Residential Code*® (2018 IRC) provisions noted in the evaluation report [ESR-4798](#) and the additional requirements of LARC Chapter 3.
- Guardrails adjacent to operable windows must comply with the requirements of City of Los Angeles Information Bulletin P/BC 2020-105.

This supplement expires concurrently with the evaluation report, reissued January 2023.

**DIVISION: 05 00 00—METALS**  
**Section: 05 52 00—Metal Railings**

**REPORT HOLDER:****IRON BALUSTER (DBA VIEWRAIL, DBA STAIR SUPPLIES)****EVALUATION SUBJECT:****EXPRESS AND SIGNATURE ALUMINUM RAILING SYSTEMS****1.0 REPORT PURPOSE AND SCOPE****Purpose:**

The purpose of this evaluation report supplement is to indicate that the Express and Signature Aluminum Railing Systems, described in ICC-ES evaluation report ESR-4798, have also been evaluated for compliance with the Chicago Construction Codes (Title 14 of the Chicago Municipal Code) as noted below.

**Applicable code edition:**2019 *Chicago Building Code* (Title 14B)**2.0 CONCLUSIONS**

The Express and Signature Aluminum Railing Systems, described in Sections 2.0 through 7.0 of the evaluation report ESR-4798, comply with Title 14B, and are subject to the conditions of use described in this supplement.

**3.0 CONDITIONS OF USE**

The Express and Signature Aluminum Railing Systems described in this evaluation report supplement must comply with all of the following conditions:

- All applicable sections in the evaluation report ESR-4798.
- The Express and Signature Aluminum Railing Systems are limited to use in Group R-5 occupancies and within individual dwelling units as outlined in Exception 1 of CBC Title 14B Section 1607.8.1.
- Systems utilizing monolithic glass infill are restricted to locations in which there is no walking surface beneath them or the walking surface is permanently protected from the risk of falling glass.
- The design, installation and inspection must be in accordance with additional requirements of Chapters 16 and 17 of Title 14B, as applicable.

This supplement expires concurrently with the evaluation report, reissued January 2023.

**DIVISION: 05 00 00—METALS**  
**Section: 05 52 00—Metal Railings**

**REPORT HOLDER:**

**IRON BALUSTER (DBA VIEWRAIL, DBA STAIR SUPPLIES)**

**EVALUATION SUBJECT:**

**EXPRESS AND SIGNATURE ALUMINUM RAILING SYSTEMS**

**1.0 REPORT PURPOSE AND SCOPE****Purpose:**

The purpose of this evaluation report supplement is to indicate that the Express and Signature Aluminum Railing Systems, described in ICC-ES evaluation report ESR-4798, have also been evaluated for compliance with the code noted below.

**Applicable code edition:**

2019 *California Residential Code* (CRC)

**2.0 CONCLUSIONS****2.1 CRC:**

The Express and Signature Aluminum Railing Systems, described in Sections 2.0 through 7.0 of the evaluation report ESR-4798, complies with CRC Chapter 3, provided the design and installation are in accordance with the 2018 *International Residential Code*® (IRC) provisions noted in the evaluation report and the additional requirements of CRC Chapter 3.

This supplement expires concurrently with the evaluation report, reissued January 2023.



**DIVISION: 05 00 00—METALS****Section: 05 52 00—Metal Railings****REPORT HOLDER:****IRON BALUSTER (DBA VIEWRAIL, DBA STAIR SUPPLIES)****EVALUATION SUBJECT:****EXPRESS AND SIGNATURE ALUMINUM RAILING SYSTEMS****1.0 REPORT PURPOSE AND SCOPE****Purpose:**

The purpose of this evaluation report supplement is to indicate that the Express and Signature Aluminum Railing Systems, described in ICC-ES evaluation report ESR-4798, have also been evaluated for compliance with the code noted below.

**Applicable code edition:**

2020 *Florida Building Code—Residential*

**2.0 CONCLUSIONS**

The Express and Signature Aluminum Railing Systems, described in Sections 2.0 through 7.0 of ICC-ES evaluation report ESR-4798, comply with the 2020 *Florida Building Code—Residential*. The design requirements must be in accordance with the *Florida Building Code—Residential*, as applicable. The installation requirements noted in ICC-ES evaluation report ESR-4798 for the 2018 *International Residential Code*® meet the requirements of the *Florida Building Code—Residential*, as applicable.

Use of the Express and Signature Aluminum Railing Systems for compliance with the High-Velocity Hurricane Zone provisions of the *Florida Building Code—Residential* has not been evaluated and is outside the scope of this supplemental report.

For products falling under Florida Rule 61G20-3, verification that the report holder's quality assurance program is audited by a quality assurance entity approved by the Florida Building Commission for the type of inspections being conducted is the responsibility of an approved validation entity (or the code official when the report holder does not possess an approval by the Commission).

This supplement expires concurrently with the evaluation report, reissued January 2023.